



Installation & Owners Manual

Envirosun® Thermosiphon Solar Water Heater



INSTALLATION RECORD

PLEASE COMPLETE THIS PAGE AS A RECORD OF THE INSTALLATION DETAILS FOR YOUR REFERENCE TO DETERMINE WHEN THE SYSTEM IS DUE FOR SERVICE OR IF A WARRANTY MATTER SHOULD ARISE.
SCAN THE QR CODE WITH YOUR PHONE AND REGISTER YOUR WARRANTY ONLINE.

Energie Group
Australia Pty Ltd
ABN 50 166 500 787
460 Victoria Road
Malaga WA 6090



IMPORTANT!
REGISTER YOUR
WARRANTY

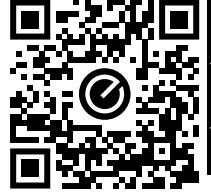

envirosun.au/warranty

.....
Owner Name

.....
Installation Address

.....
Suburb

.....
State

.....
Postcode

.....
Telephone (Home or Mobile)

.....
(Work)

.....
Email

.....
System Model Number

..... / /
Install Date

.....
Tank Serial Number

.....
Heat Exchanger Serial Number

.....
Collector 1 Serial Number

.....
Collector 2 Serial Number

.....
Collector 3 Serial Number

.....
Installer Name

.....
Installer Telephone

.....
Installer Email

.....
Installer Address or Business Name

.....
Comments

.....
Customer Signature

.....
Installer Signature

..... / /
Date

CONTENTS

IMPORTANT NOTES	2	COMMISSIONING & CUSTOMER HANDOVER	14
Interpretation of marks and symbols.....	2	Commissioning.....	14
SYSTEM OVERVIEW	2	Filling and commissioning the closed circuit jacket.....	14
Installing your new Envirosun TS System.....	2	Approved solar transfer fluids.....	14
Storage tank and solar collectors.....	2	Required equipment.....	14
Potable water use only (not suitable for pool heating).....	3	Online help.....	14
Cold climate installations.....	3	Customer handover.....	15
IMPORTANT SAFETY INFORMATION	3	ALTERNATIVE HEAT SOURCES	17
Water discharge through the pressure valve.....	3	Air source heat pumps.....	17
Warning about hot water.....	3	Benefits of heat pumps.....	17
DIMENSIONS AND TECHNICAL DATA	4	Installation considerations.....	17
System overall dimensions.....	4	Mounting and securing the tank.....	20
Tank and collector weights.....	4	Installing the heat pump.....	20
Ancillary Energy Support (AES) booster system.....	5	Heat pump system wiring.....	20
Electric AES booster system.....	5	Heat pump plumbing connections.....	20
Gas AES booster system.....	5	Cold water supply to the tank.....	21
IMPORTANT INSTALLATION INFORMATION	6	Installing the temperature sensor.....	21
Local Standards.....	6	Connecting the heat pump to the tank.....	21
Safety.....	6	PTR valve and tempering valve connections.....	21
Water quality.....	6	Tank hot water outlet.....	21
Pressure reducing valve.....	6	Main supply valve.....	21
High wind or cyclonic areas.....	7	Heat pump electrical connections.....	22
Piping material.....	7	Post installation inspection checklist.....	22
Insulation.....	7	SYSTEM MAINTENANCE	23
Vacuum break.....	7	Draining and flushing the system.....	23
Supplementary heat sources.....	7	Collector glass cleaning.....	23
Legionella requirements.....	7	Hail damage or broken collector glass.....	23
Roof location selection.....	8	Relief valves.....	23
❶ Collector orientation.....	8	No anode.....	23
❷ Shading of direct sunlight.....	8	TROUBLESHOOTING	24
❸ Storage tank location.....	8	Low solar energy input.....	24
❹ Collector inclination.....	8	Solar collector shading.....	24
❺ Roof structure.....	8	AES booster system not operating.....	24
❻ Roof area.....	8	Excessive water discharge from the valves.....	24
INSTALLATION INSTRUCTIONS	9	Hot water use higher than anticipated.....	24
Flat roof installations.....	9	Thermosiphon Arrestor valve operation (optional).....	24
Determining the mounting location.....	9	STANDARD WARRANTY	25
Installing the system.....	9	Warranty terms.....	25
Single collector system.....	9	Warranty definitions.....	25
Dual collector system.....	10	Domestic Use.....	25
Fit the hot connection pipe.....	10	Commercial Use.....	25
Fit the cold connection pipe.....	10	Warranty conditions.....	25
Cold water inlet connection.....	11	Warranty coverage.....	27
Collector cold pipe connection.....	11	Queensland, New South Wales, Victoria.....	27
Closed circuit system only.....	11	South Australia, Western Australia, Northern Territory.....	27
PLUMBING CONNECTIONS	12	Warranty exclusions.....	28
Cold water connection.....	12	OH&S Disclaimer.....	28
Cold water Expansion Control valve (ECV).....	12	CONTACT DETAILS	28
Hot water connection.....	12	APPENDIX	31
Pressure & Temperature Relief valve (PTR).....	12	Solid fuel booster (wetback) option.....	31
Electrical connection for electric booster (AES).....	12	Installation requirements and warnings.....	31
Gas booster (AES) installation instructions.....	13		
Approved gas booster models.....	13		

IMPORTANT NOTES

Interpretation of marks and symbols

Failure to follow these instructions may lead to serious malfunctions of the device and danger to the user.



Important information is highlighted with this symbol.



CAUTION

Instructions marked with this symbol indicate additional care should be taken when performing the instructed task or activity.



Instructions with this symbol relate to important installation requirements that ensure the correct operation of the device.



WARNING

Instructions marked with this symbol must be followed. Failure to do so may lead to product damage and harm to the user.

SYSTEM OVERVIEW

Installing your new EnviroSun TS System

This manual provides you with the essential information needed to install and operate the EnviroSun Thermosiphon System correctly. Please read it carefully and follow all the instructions.

Storage tank and solar collectors

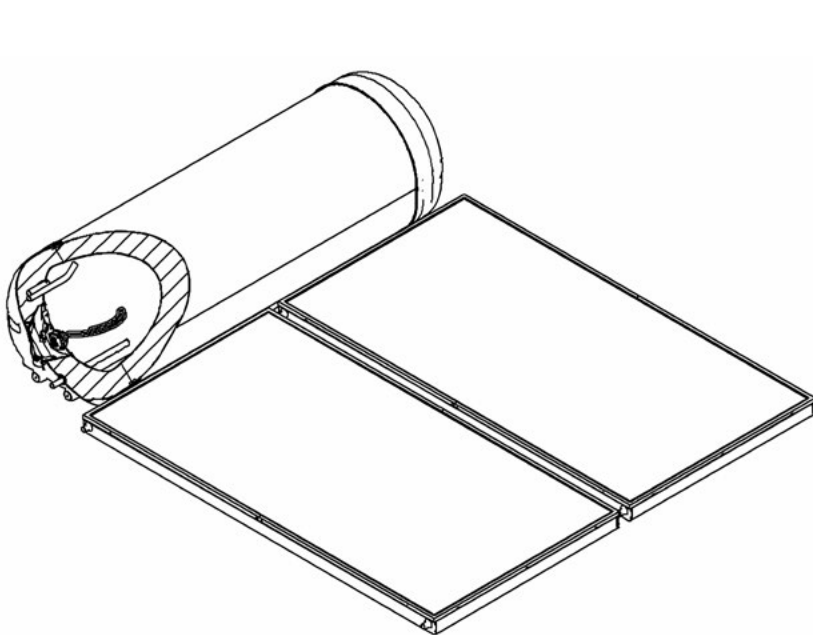

Figure 1. Typical system layout

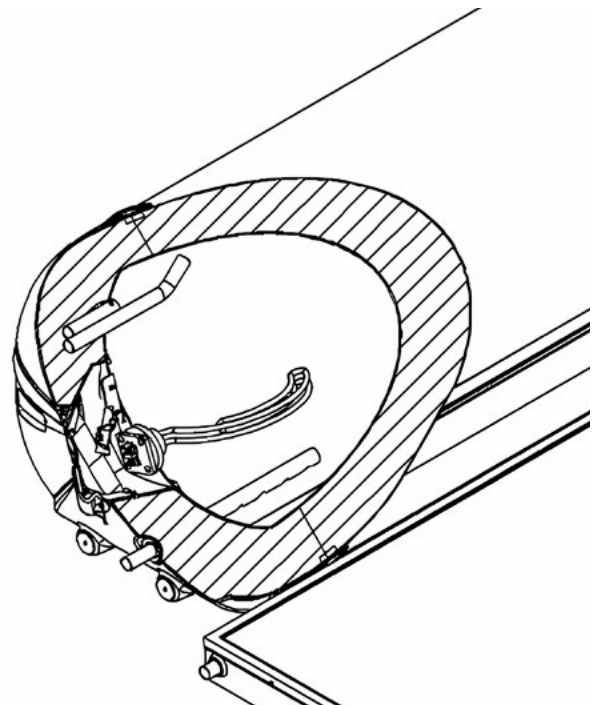

Figure 2. System layout detail (cutaway)

The tank stores the heated water ready for household use. TS Plus tanks are made from 444 grade stainless steel to provide long life. 444 Stainless steel is a ferritic stainless steel with very good corrosion resistance and is designed for water tanks. The tank is insulated with high density polyurethane foam to ensure minimal heat loss and maximum structural strength. The case is made from prepainted zinc coated steel (PPGI) with stylish UV protected polypropylene end caps.

Envirosun solar collectors contain copper waterways bonded to a solar absorber plate. The collectors absorb solar energy and transfer it to the fluid. The absorber is enclosed in an aluminium casing, covered with high-strength toughened low iron glass.

Potable water use only (not suitable for pool heating)



Envirosun TS systems are designed for domestic and commercial potable hot water use. They are not suitable for heating pool water or other chemically treated water.

Cold climate installations

If you are in a frost prone or freeze area you must install a closed circuit system. The open circuit system is not suitable for frost prone or freeze areas. Only closed circuit models are warranted against freezing.

If the unit is to be fitted in areas prone to frost and freezing the unit must be installed in accordance with any relevant sustainability programme (such as the Sustainability Victoria program). Closed circuit tanks must be installed and charged in accordance with Envirosun requirements and only Envirosun ST-5 heat transfer fluid can be used. Transfer fluid used must be warranted against frost and freezing.



WARNING

Only closed circuit systems are warranted in the event of damage caused by frost or freezing. Closed circuit systems must be installed in accordance with this manual and properly commissioned to be covered by warranty.

IMPORTANT SAFETY INFORMATION

Water discharge through the pressure valve

All Envirosun solar water heaters have two pressure valves located within the system configuration. The cold water Expansion Control valve (ECV), located in the cold water supply pipe, may release a small amount of water from time to time during the heating cycle of the system.

The water discharge is water expanding due to the heating process. Normally the discharge will be less than 10L per day but can be more depending on the water usage and the temperature rise. The PTR valve, located on the storage tank, may also release a small expansion discharge. These drain pipes must be left open to the atmosphere.

Warning about hot water

Water heaters have the ability to produce hot water very quickly. To reduce the risk of scald injury it is a requirement that a temperature control valve be fitted to the hot water supply pipework. This valve should be checked **every 6 months** to ensure its operation and settings remain correct.

Check that the Pressure & Temperature Relief (PTR) valve drain pipe is not located where it can cause damage if hot water is discharged.

! WARNING ABOUT HOT WATER !

Heated water can be dangerous, especially for young children and the infirm. Water temperatures above 50°C can cause severe burns instantly and may even result in death. Those most at risk are children, disabled, elderly and the infirm.

Hot water at 60°C can severely burn a child in less than half a second, at 50°C it takes five minutes.

ALWAYS

Always test the temperature of the water with your elbow before placing a child in the bath; also carefully feel water before bathing or showering yourself. Supervise children whenever they are in the bathroom. Make sure that the hot water tap is turned off tightly.

CONSIDER

Consider installing child proof tap covers or child resistant taps (both approaches will prevent a small hand being able to turn on the tap), and setting the appliance at a maximum temperature of 50°C.

NEVER

Never leave a toddler in the care of another child. They may not understand the need to have the water temperature set at a safe level.

DIMENSIONS AND TECHNICAL DATA

System overall dimensions

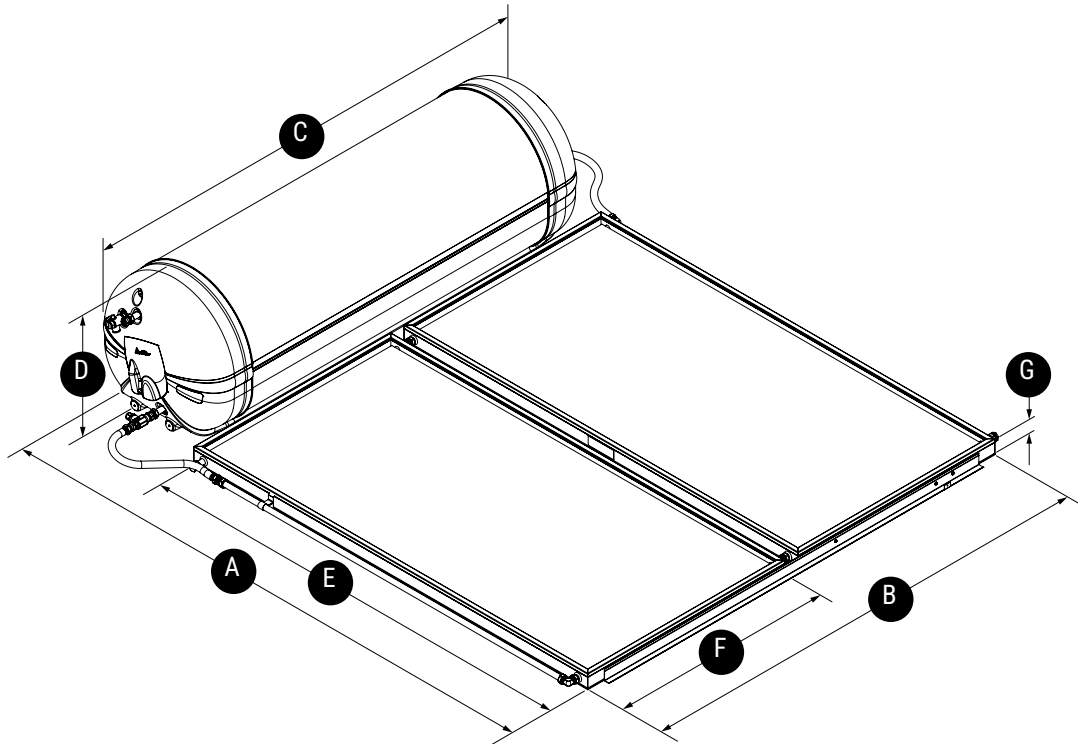

Figure 3. 300L System overall dimensions

Model Number	Dimensions (mm)						
	A	B	C	D	E	F	G
TS170/25/O///E20	2600	-	1220	586	2000	1000	70
TS170/25/O///E25	2600	-	1200	586	2000	1235	70
TS300/25/O///E25	2600	1370	2010	586	2000	1235	70
TS300/40/C///E20	2600	2238	2010	737*	2000	1000	70
TS300/40/O///E20	2600	2238	2010	586	2000	1000	70
TS300/50/C///E25	2600	2645	2010	737*	2000	1235	70
TS300/50/O///E25	2600	2645	2010	586	2000	1235	70
TS300/60/O///E20	2600	3260	2010	583	2000	1000	70

Tank and collector weights

Tank	Material	Weight – Empty (kg)	Weight – Full (kg)
TS170/O/E24/S	444 Stainless Steel	36	206
TS300/O/E24/S	444 Stainless Steel	59	359
TS300/C/E24/S	444 Stainless Steel	77	388

Collector	Weight – Empty (kg)	Weight – Full (kg)
E20HA	27.5	29.2
E20HS	27.5	29.2

Ancillary Energy Support (AES) booster system

Electric AES booster system

The Ancillary Energy Support (AES) may be either electric or gas boosting. AES systems use an electric element to heat part of the stored water when there is reduced solar energy available e.g. cloudy days. Electric AES systems are automatically controlled by an internal thermostat allowing the electric element to operate only if the stored water temperature falls below 60°C. At 60°C the thermostat will turn the AES off.

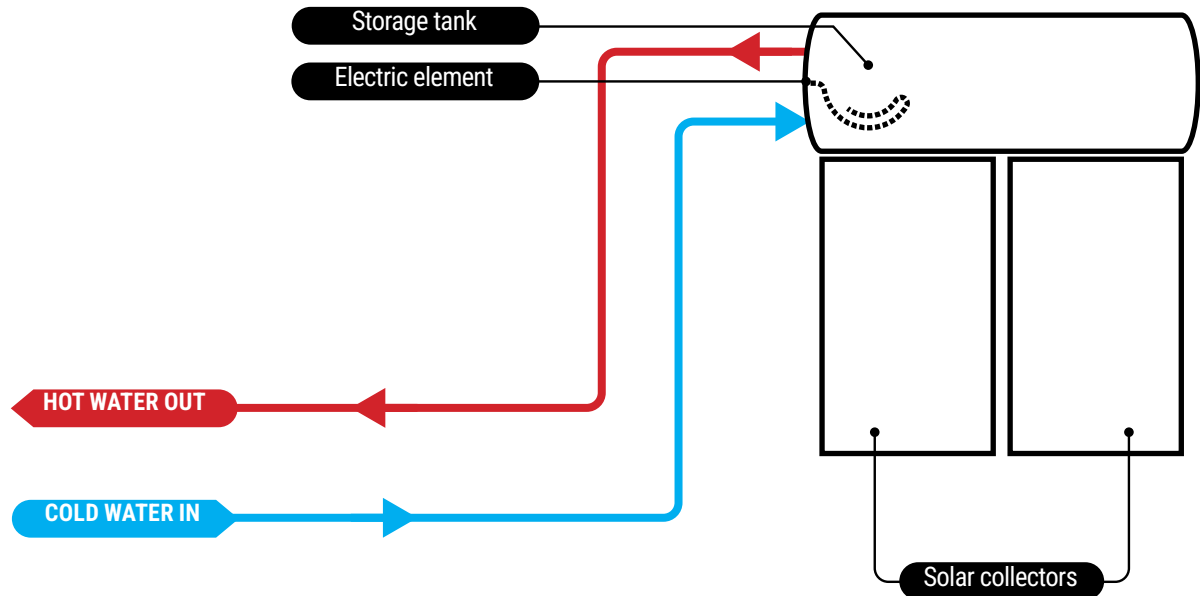

Figure 4. Electric AES system schematic

Gas AES booster system

Gas AES systems use a continuous flow gas water heater fitted in series with the hot water supply from the storage tank. As the hot water passes through the gas heater its temperature is automatically monitored. If the temperature is below 70°C, the gas heater will add the heat required to deliver hot water of at least 70°C. If the water temperature is above 70°C, the gas heater is programmed to not ignite.

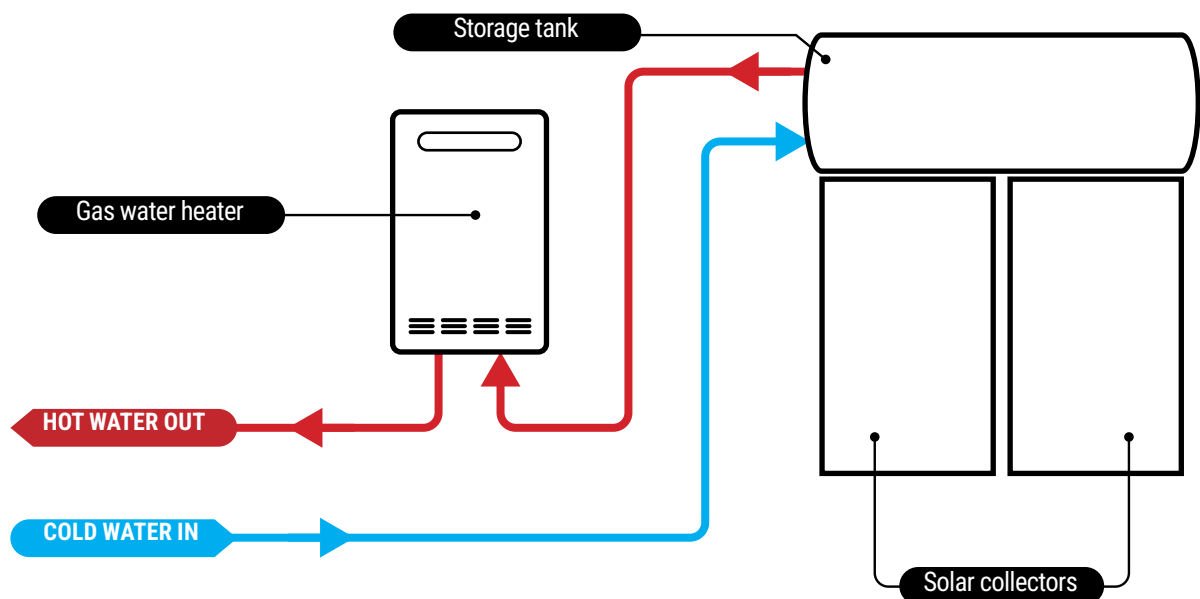

Figure 5. Gas AES system schematic

IMPORTANT INSTALLATION INFORMATION

Local Standards

The following standards and regulations must be taken into account when planning the installation of the EnviroSun TS solar water heater.

- AS/NZS 3500.4.2 National plumbing and drainage code hot water supply systems – acceptable solutions.
- HB 263-2004 heated water systems plumbing industry commission.
- AS/NZS 3000 Electrical installations (known as the Australian/New Zealand wiring rules).
- Any local regulations that govern this type of installation.
- This product conforms with the Lead Free requirements of the National Construction Code Volume 3, PCA.

Where these instructions and any local regulations are in conflict, the local regulations shall prevail.

Safety

Do not commence any aspect of this installation until you have satisfied yourself that all safety issues have been addressed.



WARNING

This installation should only be performed by an approved professional with suitable experience and licenses, authorised by EnviroSun to conduct the work.

It is imperative that installers adhere to Occupational Health & Safety Guidelines at all times. The installer is responsible for their safety and the safety of those around them.

Water quality

Water supply from an unfiltered water source that is highly conductive or has a high mineral content may void the system warranty.

To ensure water quality guidelines are met, the following characteristics should not be exceeded.

Water Properties	Acceptable Levels
Total hardness	200 mg/litre or ppm
Total Dissolved Solids (TDS)	600 mg/litre or ppm
Chloride	250 mg/litre or ppm
Magnesium	10 mg/litre or ppm
Sodium	150 mg/litre or ppm
pH Min	6.5 to Max 8.5
Electrical conductivity	850 µS/cm

In areas of poor water quality, it is recommended that a softener, conditioner or similar device be fitted to the water supply.

A breach of this condition may void the warranty in the event of damage caused by water quality exceeding these characteristics.

Pressure reducing valve



WARNING

All EnviroSun systems are supplied with a 500 kPa pressure reducing valve. This must be installed on the cold water supply line to the water heater system.

A breach of this requirement may void the warranty in the event of damage caused by excessive pressure.

Minimum supply pressure

Open circuit systems must have a minimum supply pressure of 200 kPa at the tank inlet. Closed circuit systems must have a minimum supply pressure of 300 kPa at the tank inlet.

High wind or cyclonic areas

The standard mounting system is designed for standard roof installations of either metal or tile construction. It may be necessary to use the cyclone mounting system if one of the following applies:

- The collector must be installed between 1m and 0.5m (minimum) from the roof edge or peak.
- The installation has minimal shielding from surrounding buildings and trees, or is located on a hill or similar locations that may cause high wind effects. Refer to Terrain Categories, Topographic Effects & Shielding Factors in AS 1170.2:2002 or consult a structural engineer.
- The installation is on a roof with a pitch greater than 30°.



WARNING

If the solar water heater is installed in an area classed as Cyclone Region C or D according to AS 1170.2:2002, the standard mounting systems must not be used. Please consult a structural engineer for advice on ensuring the installation will comply with local building codes and regulations. EnviroSun has approved cyclone frames for these applications.

Piping material



CAUTION

EnviroSun recommends the use of copper pipe, certified to AS 1432, in the flow and return lines to the solar water system.

Plastic piping is not to be used for any portion of the water heater system plumbing unless the pipe manufacturer has rated it for temperatures up to 99°C at 600 kPa, or a tempering valve installed to ensure the water does not exceed the pipe temperature and pressure ratings. A minimum pipe run of 4m in copper is required between the water heater and any plastic piping.

Insulation

Hot and cold lines to the storage tank must be insulated according to the requirements of AS/NZS 3500.4. Insulation material should be of a closed cell type and have a minimum R value of 0.36 and thickness of 10mm. Thicker insulation may be required in certain locations. Insulation should be suitable for solar working temperatures. Insulation installed externally must be weatherproof and UV resistant.

If installing a TS300/25/0/XX/S2/E25BC system, the collector flow and return piping must be insulated with the supplied insulation to comply with the Clean Energy Regulator (CER) modelling.

Vacuum break

For installations on a house of 3 storeys or more, a vacuum break must be installed at the highest point of the hot outlet line. This will prevent damage to the storage tank in the event of an unexpected loss of water supply pressure causing system drain down and the formation of a partial vacuum.

Supplementary heat sources

If a supplementary heat source is connected to the storage tank, the maximum energy input cannot be more than 10 kW, including the electrical element. Where greater input is required a pressure and temperature relief valve with a higher kW rating must be fitted to the storage tank.

Where stove coils are used for supplementary heating the water must be connected in an open vented manner. Refer to Australian Standard AS 3500 for more details on acceptable connection solutions.

Any supplementary heat source must be limited such that the maximum tank temperature is 80°C.

Legionella requirements

Australian Standards require that a water heater system provide a means to inhibit the growth of the Legionella bacteria in potable water.

Systems installed with an approved gas AES, with the outlet temperature set to 70°C, satisfy this requirement.

Systems with an electric AES, must meet one of the following requirements:

1. Minimum of 45% of the storage volume heated to 60°C daily. This can be achieved by leaving the AES permanently on.
2. Minimum of 90% of the storage volume heated to 60°C for 32 minutes in each 7 day period. This requires a timing device.

Roof location selection

1 Collector orientation

For optimum performance select a roof surface oriented less than 45° away from the equator (in the southern hemisphere the equator is north and in the northern hemisphere it is south). Installations orientated up to 45° away from the equator do not have a major effect on the annual solar output. If the location has an east facing bias, the best solar input is achieved in the morning. If the location is a west facing bias, the best solar input is in the afternoon.

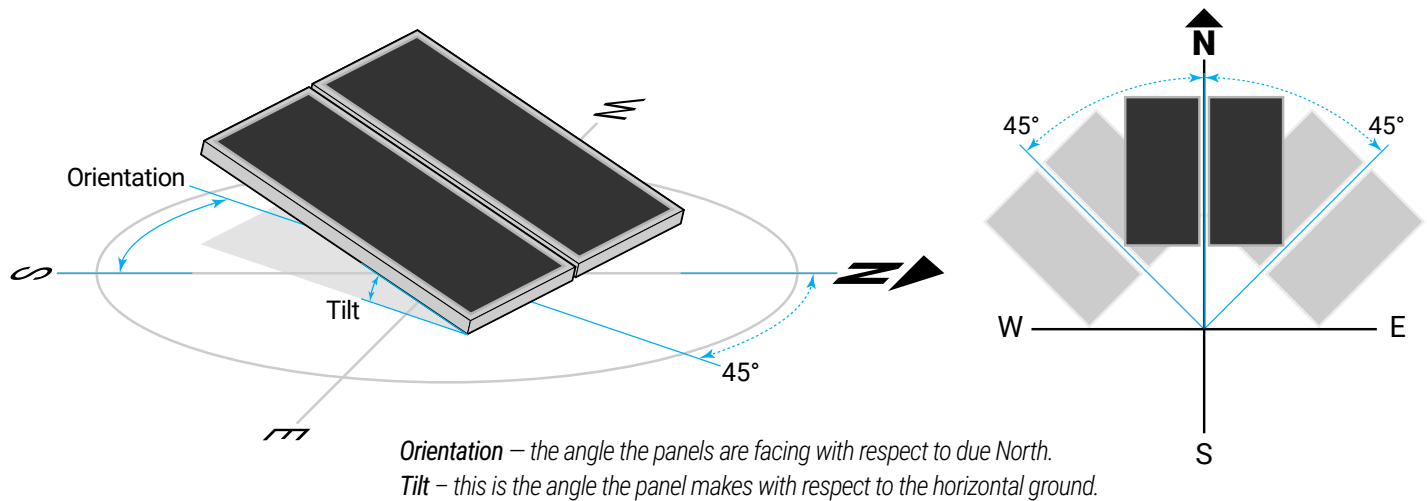

2 Shading of direct sunlight

Inspect the site carefully to ensure the selected location is not subject to shading from adjacent trees or buildings throughout the day, particularly between 9am and 3pm. Shadows are longer in winter than in summer so a site that is free of shadows from adjacent objects in summer may have some shadows in winter.

3 Storage tank location

Locate the water heater as close as possible to the largest hot water demand, e.g. the bathroom or kitchen. This reduces energy loss through the pipework.

4 Collector inclination

Check that the roof pitch is greater than 10° and less than 30°. Installations on a pitch greater than 30° will require additional support at the storage tank to prevent it moving downward. Where the pitch is less than 10° the system will require a mounting frame to increase the pitch. Installations below 10° do not thermosiphon effectively and the collector glass will not self-clean during rainy periods.

5 Roof structure

Envirosun TS hot water systems can be installed on metal or tile roofs. Ensure the roofing material and roof structure are capable of supporting the full load of the storage tank, collectors and trades personnel during installation. The structure should be capable of supporting a 250kg point load. If this is not the case, additional bracing must be installed before proceeding with the installation.

6 Roof area

The system should be located 1m from all roof edges and peaks. A minimum distance of 0.5m is required around the system to ensure adequate working access. Sufficient distance must be allowed up the roof from the storage tank for securing the mounting straps.

INSTALLATION INSTRUCTIONS

Before starting the installation, please check carefully to ensure all items are accounted for.



Before commencing the installation of the solar water heater system ensure you have familiarised yourself with the Important Installation Information requirements on page 6.



Carefully remove all packaging and protective coatings and dispose of them in an appropriate manner. This includes the plastic core-strip from the top and bottom of the tank and from the back of the collector when mounted on a pitch frame, the plugs from the collector, and storage tank connection pipes.

Flat roof installations



For flat roof installations a special mounting frame (82-825-009) is required. After the frame has been assembled, follow the instructions as outlined below.

Determining the mounting location



1. The starting point for the installation is the storage tank front foot. Locate the tank centrally over at least two (2) rafters or trusses, with the front directly over a tile batten or purlin. The batten or purlin selected must be located at least 2.4m up from the lower edge of the roof and 1m down from the roof ridge line.
2. From the selected batten/purlin, measure 2m down the roof slope. This position will be the bottom edge of the collector mounting rail (*Figure 8*).

Installing the system

3. Take care with all pipe compression connections to prevent twisting of pipes. EnviroSun systems use 22mm compression fittings so it is good practice to have spare fittings on hand to guard against loss of parts when on site.
4. Place one end of the collector mounting rail at the location marked in Step 2 above. Lay the rail horizontally across the roof, centrally over the rafters/trusses.
5. Locate two roof trusses under the collector mounting rail (as near as possible to the outer edges of the rail). Slide two collector straps onto the collector mounting rail where the trusses pass under the mounting rail.
6. Adjust the mounting rail so that it is horizontal across the roof, then raise it by 5–10 mm on the right side to assist thermosiphon flow circulation.
7. Screw fix the collector straps to the roof trusses using the pre-punched holes in the collector straps.
8. Place the first collector on the collector mounting rail.

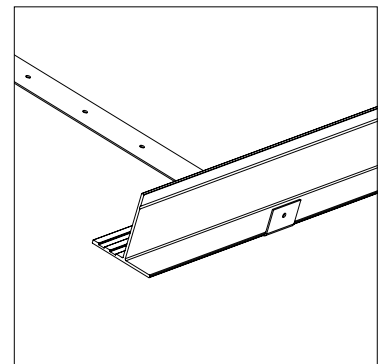

Figure 6. Collector rail mounting

Single collector system

9. Skip to Step 15.

Dual collector system

10. Loosely fit the two collector connectors to the two copper tube spigots on the right side of the collector array.
11. Place the second collector onto the collector mounting rail (*Figure 8*).
12. Slide the second collector towards the first collector until the two copper tube spigots slide fully inserted into the collector connectors.
13. Tighten the compression nuts of the collector connector fittings. Use correctly sized spanners, hold the fitting centre whilst tightening the compression nuts.
14. Ensure that the collector(s) are centred on the mounting rail.
15. Fix the collector rail to the collectors with two (2) of the supplied self-drilling screws per collector into the groove in the rail (*Figure 8*).
16. Slide a compression plug assembly (*Figure 9*) onto the top left and bottom right connections of the collector array. Tighten the assemblies.
17. Hook the tank straps into the slot on the collector- tank bracket and fold down.
18. Place the two collector-tank brackets, with straps, on each collector, lining them up with the roof trusses. They must be no more than 1.5m apart and between the black tank ends. Fasten the bracket to collectors with supplied screws.
19. Screw the bracket to the top of the collector using the hex screws supplied.
20. Place the tank centrally above the collector array, at the position identified in Step 1 above. Move the tank so that the tank foot fits into the bracket.
21. Secure the two (2) tank clamps behind the tank to the bolt fixed to the tank strap using the larger and smaller washers and the nut. Screw fix the tank clamps to the tank using the two (2) self-drilling screws provided (*Figure 10*).
22. Screw-fix the tank straps to the rafters.

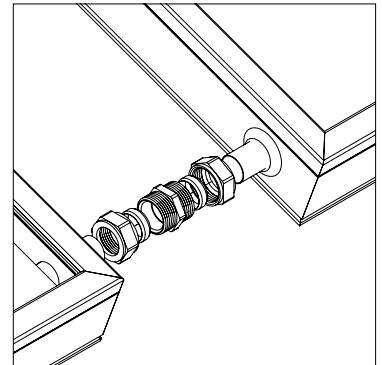

Figure 7. Collector connectors

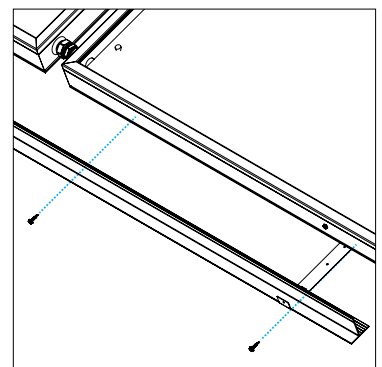

Figure 8. Collector mounting

Fit the hot connection pipe

23. This procedure will differ between models, refer to the appropriate picture:
 - **Open Circuit System** – see *Figure 11*
 - **Closed Circuit System** – see *Figure 12*
 Note that the probe on the TAV points away from the tank.
24. Slide the appropriate compression unions/elbows onto the tank and collector pipes. Tighten the assembly. Insert one end of the connection pipe to the collector union/elbow, gently bend the pipe and insert to the tank union. Tighten the connection assemblies.

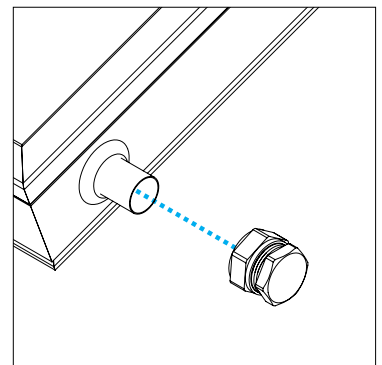

Figure 9. Compression plug

Fit the cold connection pipe

- **Open Circuit System** – see *Figure 13*
Slide the compression elbow onto the bottom left corner of the collector array. Tighten the assembly.
 - **Closed Circuit System** – see *Figure 14*
Slide the combined elbow/fill fitting onto the bottom left corner of the collector array. Tighten the assembly.
25. Fit the collector end of the cold-side rigid pipe into the elbow. Tighten the assembly onto the connection pipe.
 26. Slide an Rp^{3/4}" compression union onto the hot outlet of the tank. Tighten the assembly. Insert the PTR valve supplied with the Parts Kit into the valve port in the tank (*Figure 15*).

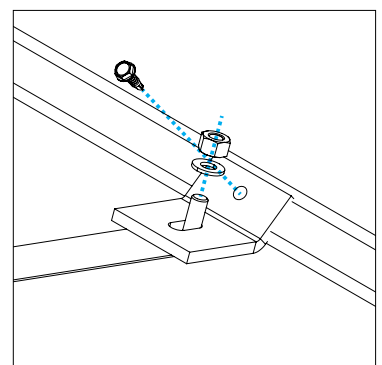

Figure 10. Tank clamp

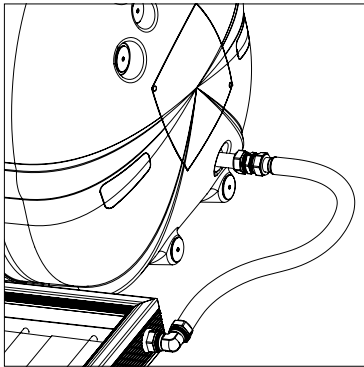

Figure 11. Hot pipe (open circuit)

Cold water inlet connection

- **Open Circuit System** – see *Figure 15*
Install the TA valve 22mm x C¹/₂ x 22mm to the cold inlet pipe of the tank.
- **Closed Circuit System** – see *Figure 17*
Slide an Rp ³/₄" compression union onto the cold inlet of the tank. Tighten the assembly.

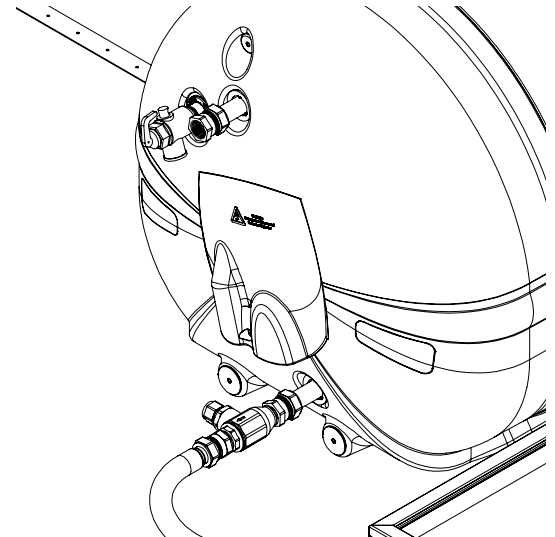

Figure 15. Connection end (open circuit)

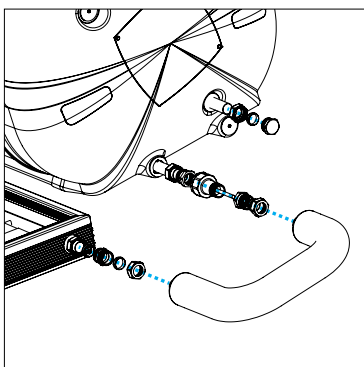

Figure 12. Cold pipe (closed circuit)

Collector cold pipe connection

- **Open Circuit System**
Insert the cold-side rigid pipe into the TAV. Tighten the assembly.
- **Closed Circuit System**
Slide the test point assembly union onto the closed circuit connection, tighten the assembly. Insert the tank end of the cold-side rigid pipe into the 22 mm connection union (*Figure 16*).

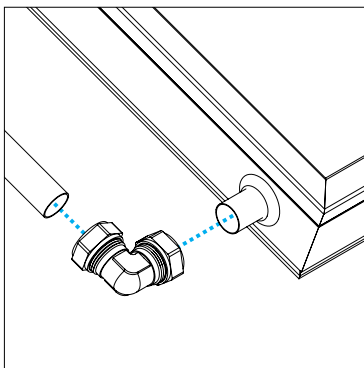

Figure 13. Cold pipe (open circuit)

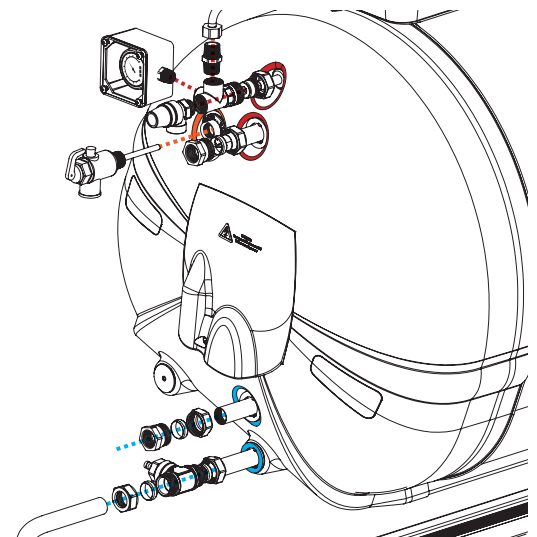

Figure 16. Connection end (closed circuit)

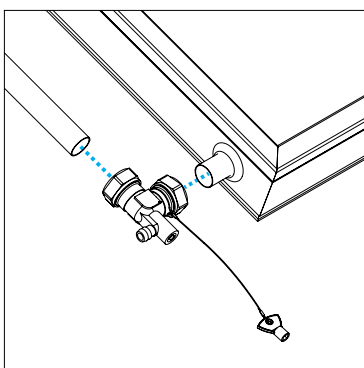

Figure 14. Cold pipe (closed circuit)

Closed circuit system only

- **Expansion Tank Installation** – see *Figure 17*
Screw the jacket valve assembly into the vent connection at the top of the tank on the left-hand side. Connect the expansion tank to the valve assembly with the flexible connector.
- Secure the expansion tank to the TS tank using the hook and loop straps.
- Place the cover over the expansion tank and secure in place using the supplied screws.
- Insert the PTR into the front connection of the valve assembly and the pressure gauge into the left connection.

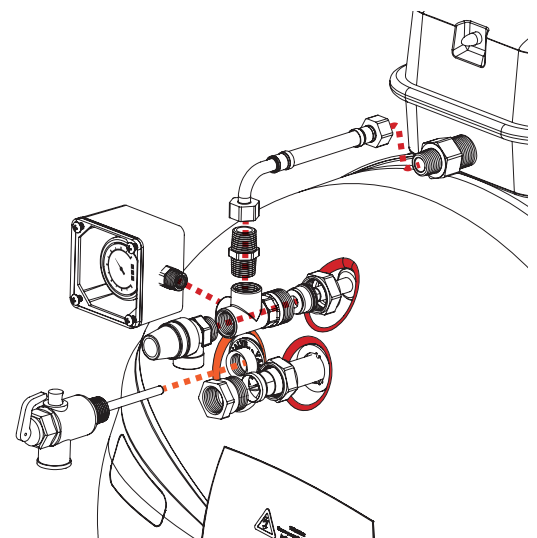

Figure 17. Expansion tank connection

PLUMBING CONNECTIONS

Cold water connection



A check valve and a stop cock must be fitted to the cold water supply pipework.

1. The cold water connection is made at the blue disc. Connect the cold water supply to the end of the $\frac{3}{4}$ " BSP female thread of the T-piece in the cold pipe assembly (see *Figure 16*).
2. Where the water supply pressure is likely to exceed 550 kPa at any time, a 500 kPa pressure reducing valve (PRV) must be fitted to limit the supply pressure. The PRV is supplied with each Parts Kit.

A breach of this requirement may void the warranty in the event of damage caused by excessive pressure.

Cold water Expansion Control valve (ECV)



Fit the 600 kPa pressure relief valve, supplied in the Parts Kit, in the cold water supply pipe after the supplied check valve/stop cock/pressure limiting combo valve.

Hot water connection



Use the $\frac{3}{4}$ " BSP x 22mm fitting, supplied in the Parts Kit, to connect the hot water supply to the storage tank outlet connection marked with a red disc.

Pressure & Temperature Relief valve (PTR)



CAUTION

Run the PTR valve discharge line to a safe location. **Never discharge onto a solid surface like concrete as it can discharge very hot water.**

1. Fit the 700 kPa/99°C (10 kW) Pressure & Temperature Relief valve supplied in the Parts Kit into the $\frac{1}{2}$ " tank socket, marked with the brown disc, near the hot outlet tube as shown in.
2. Ensure that the drain line from the pressure and temperature relief has a continuous downslope and falls away from the valve, towards the ground level to a safe location, terminating above the ground level. Ensure that the drain is installed in a place where it cannot be affected by freezing conditions (per AS 3500).



Electrical connection for electric booster (AES)



WARNING

Envirosun water heaters are fitted with a thermostat and an over temperature cutoff for safety. These devices should not be tampered with or removed.

Do not operate this water heater without the electrical thermostat and over temperature cutoff in the circuit.

The electric element is only connected in models using an electric AES system. No connection is made to the electric element for gas AES systems. The AES requires a 220–250V single-phase AC power supply with a capacity suitable for the kilowatt rating of the element selected for the application. For example, a 2.4 kW element requires a 10A supply capacity, a 3.6 kW element requires 15A supply capacity.

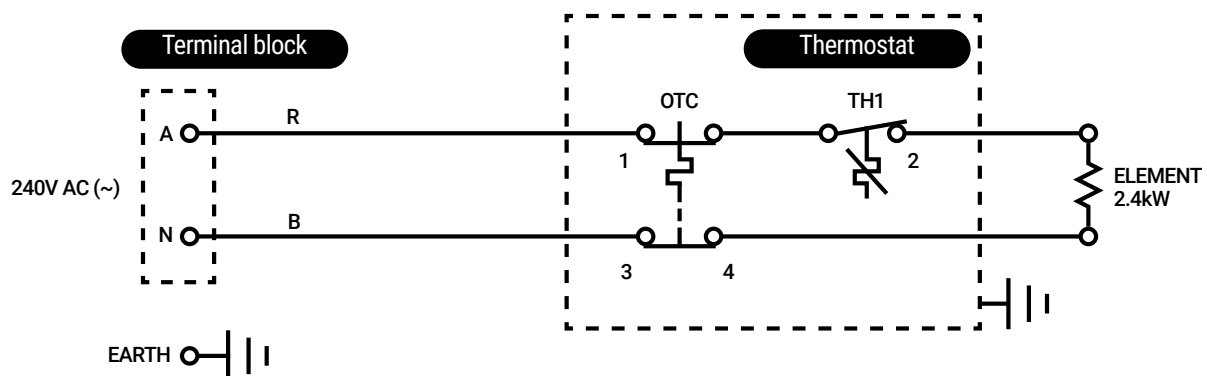





Figure 18. Electrical circuit diagram



The power supply must be protected by an individual fuse or circuit breaker rated to suit the booster size.

The electrical supply to the solar water heater can be operated directly from the switchboard or via a remotely mounted switch or time clock as requested by the customer. A means for disconnection (e.g. isolator) must be included in the fixed wiring to the solar water heater in accordance with the wiring rules.

Final electrical connection at the solar water heater is as follows:

-  **EARTH** (green/yellow) – connected to the earthing stud marked with E or the earth \perp symbol;
-  **ACTIVE** (brown/red) – connected to the terminal block position marked A or Active;
-  **NEUTRAL** (blue/black) – connected to the terminal block position marked N or Neutral.



Do not turn on the power supply until the solar water heater has been filled with water and pressurised. There is a risk of damage to the system if the installation sequence is not followed.

Gas booster (AES) installation instructions

- All gas work must comply with local regulations including AS 5701/AG601 and AS/NZ:3500.4
- All gas work must be conducted by a suitability licensed gas fitter.
- Installation of the gas heater must be in accordance with the installation instructions supplied with it.
- Particular attention must be given to the gas supply to ensure there is a sufficient gas supply available to the gas heater when operating at full output burner rate.

Approved gas booster models

- Gas heater models used with Envirosun solar water heater systems must be certified to all local requirements, be automatic ignition and have full flame modulation.
- The temperature setting of the gas AES must be permanently set to 70°C.
- Gas heaters other than this type **must not be used** with an Envirosun solar water heater. Please refer to your local distributor for information on approved gas heater model.



FIXED PILOT AND FIXED FLAME GAS HEATER MODELS MUST NOT BE USED UNDER ANY CIRCUMSTANCE.

COMMISSIONING & CUSTOMER HANDOVER

Commissioning

When all connections have been completed the solar water heater can be filled with water.



1. Before turning on the cold water supply to the system, open one hot tap within the household to release air from the system during the filling process. Do not leave the open tap unattended during the filling process.
2. Turn on the cold water supply and wait for the system to fill.
3. When water flows from the open hot tap without air bursts the hot tap can be closed. This will now pressurise the solar water heater system.
4. Once the system is pressurised, all connections on the water heater must be checked for leaks and repaired if necessary.
5. When the system is proven water tight, power and/or gas can be applied to the AES system.
6. To test that the element is operational turn the circuit breaker in the switch board on and off, you should see the power meter's speed change during this action.
7. For gas AES systems, turn on a hot water tap and the gas heater will ignite provided the water temperature is less than 70°C.

Filling and commissioning the closed circuit jacket



When filling the jacket with glycol it is essential that the main tank is filled with water and pressurised prior to filling the closed circuit. Refer to Commissioning section above.

CAUTION

Do not fill the closed circuit system with any toxic solution. There is a real risk to public health if the wrong solar glycol solution is used. The solar transfer fluid is of food grade and non-toxic. However, care must be taken when handling not to spill or accidentally consume. Always use the solar transfer fluid as specified under Approved Solar Transfer Fluids.

Approved solar transfer fluids

- Name: **ST-5 Solar Transfer Fluid**
- Description: **Propylene Glycol**
- Appearance: **Red liquid**



To ensure adequate frost protection use a complete 4.5L litre bottle of ST-5. This will maintain glycol above 40% of solution.

Required equipment

1. Square key (attached to fill fitting)
2. ST-5 solar transfer fluid supplied with the system.
3. Commissioning kit supplied with the system. Contains one each of the following:
 - a. 3m length of 10mm hose
 - b. 1/2" cap
 - c. 1/2" plug
 - d. Bicycle pump
 - e. Pelican pump

Online help

Details on commissioning the THX Plus system can be viewed on our web page at envirosun.au or you can watch helpful videos on our YouTube channel at youtube.com/@envirosun.

The direct link to our YouTube videos is youtube.com/@envirosun/videos or search "youtube + envirosun" in your preferred search engine.



Procedure



Cover the collectors for this procedure to prevent pressure variation. Ensure all fittings remain visible.

1. Remove the braided hose from the 1/2" nipple on the Jacket Valve Assembly.
2. Fill the closed circuit with water: connect a hose from the PTR valve drain line on the tank to the fill port on the bottom left of the collector array (see *Figure 15, page 11*). Open the fill port using the square key. Lift the test arm on the valve to fill the closed circuit.
3. Once the closed circuit is filled, water will flow freely, without air, through the 1/2" nipple from Step 1. Drop the test arm of the valve to turn off the water to the closed circuit.
4. Place a cap on the 1/2" nipple and a plug in the jacket valve discharge.
5. Use a bicycle pump, connected to the test point (*Figure 19*) to pressurise the closed circuit to 100 kPa. Hold pressure for 10 minutes. Check the closed circuit for any connection leaks or drop in pressure. Ensure the collectors remain covered. Tighten any leaking fittings.
6. Once confirmed that the closed circuit has no leaks, remove the plug from the closed circuit relief valve and the cap from the 1/2" nipple in Step 4. Release the pressure at the closed circuit relief valve, then open the fill port to drain the water from the closed circuit.
7. Remove the cap from the bottle of ST-5 heat transfer fluid, and replace with the pelican pump and hose assembly. Attach the other end of the hose to the fill port.
8. Pump all of the transfer fluid into the closed circuit and close the fill port.
9. Remove the hose from the fill port, and replace with the water hose.
10. Open the fill port and pull the release lever on the PTR valve to fill the system with water.
11. Close the fill port. Remove the hose from the fill port and the PT Valve outlet.
12. Reconnect the braided hose to the jacket valve assembly, ensuring it is tightened correctly.
13. Uncover the collectors.

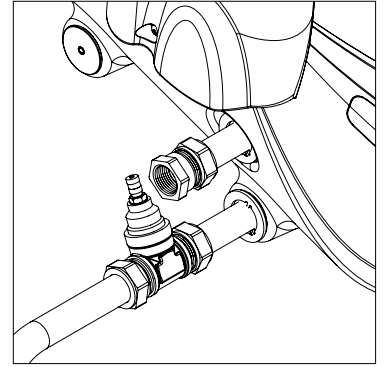

Figure 19. Test point assembly

Customer handover

The solar water heater is now fully operational.

Once the solar water heater is commissioned and you are confident it is operating correctly, the owner can complete the installation details at the beginning of this manual or scan the QR code to complete the Installation Record and Warranty Registration online.

Please hand the owner this Installation & Owners Manual, Commissioning Kit and Gas Heater Manual (if gas AES is used). Before leaving the installation, ensure that the customer is fully aware of the system's operation and whom to contact should there be any questions in the future. Contact details are listed on page 28.

Thank you for installing our world class EnviroSun solar water heater!

THIS PAGE INTENTIONALLY LEFT BLANK

ALTERNATIVE HEAT SOURCES

Thermosiphon solar hot water systems are designed for optimal energy efficiency. Traditionally, solar collector panels harness energy from the sun to heat water. However, we now offer an alternative heat source; an air source heat pump, to provide reliable and energy-efficient water heating regardless of sunlight availability.

Air source heat pumps

Heat pump hot water systems consist of a compressor and a storage tank. Air source heat pumps operate like a refrigerator in reverse, extracting heat from the surrounding air to heat water in the tank. This process enables efficient water heating, even in colder temperatures. The unit can supply in excess of five units of heat energy from ambient air for every unit of electricity it consumes, meaning the cost of energy used to produce hot water is minimised.

Benefits of heat pumps

- **Energy efficiency:** Produces over five units of heat for every unit of electricity consumed.
- **Year-round performance:** Functions effectively in all weather conditions, night or day, requiring no solar exposure.
- **Lower operating costs:** Paired with a solar PV system, heat pumps operate on solar energy, significantly reducing electricity costs.
- **No booster required:** Unlike traditional solar hot water systems with electric or gas boosters, heat pumps operate efficiently without additional heating elements.
- **Environmentally-friendly:** Uses an ozone-friendly refrigerant with minimal environmental impact.

Installation considerations

- **Positioning:** The heat pump should be installed in a well-ventilated outdoor space to maximise heat absorption.
- **Plumbing compatibility:** The system connects seamlessly to TS Plus 300L and 170L hot water storage tanks.
- **Power supply:** Requires a standard electrical connection, which can be offset by solar PV if available.

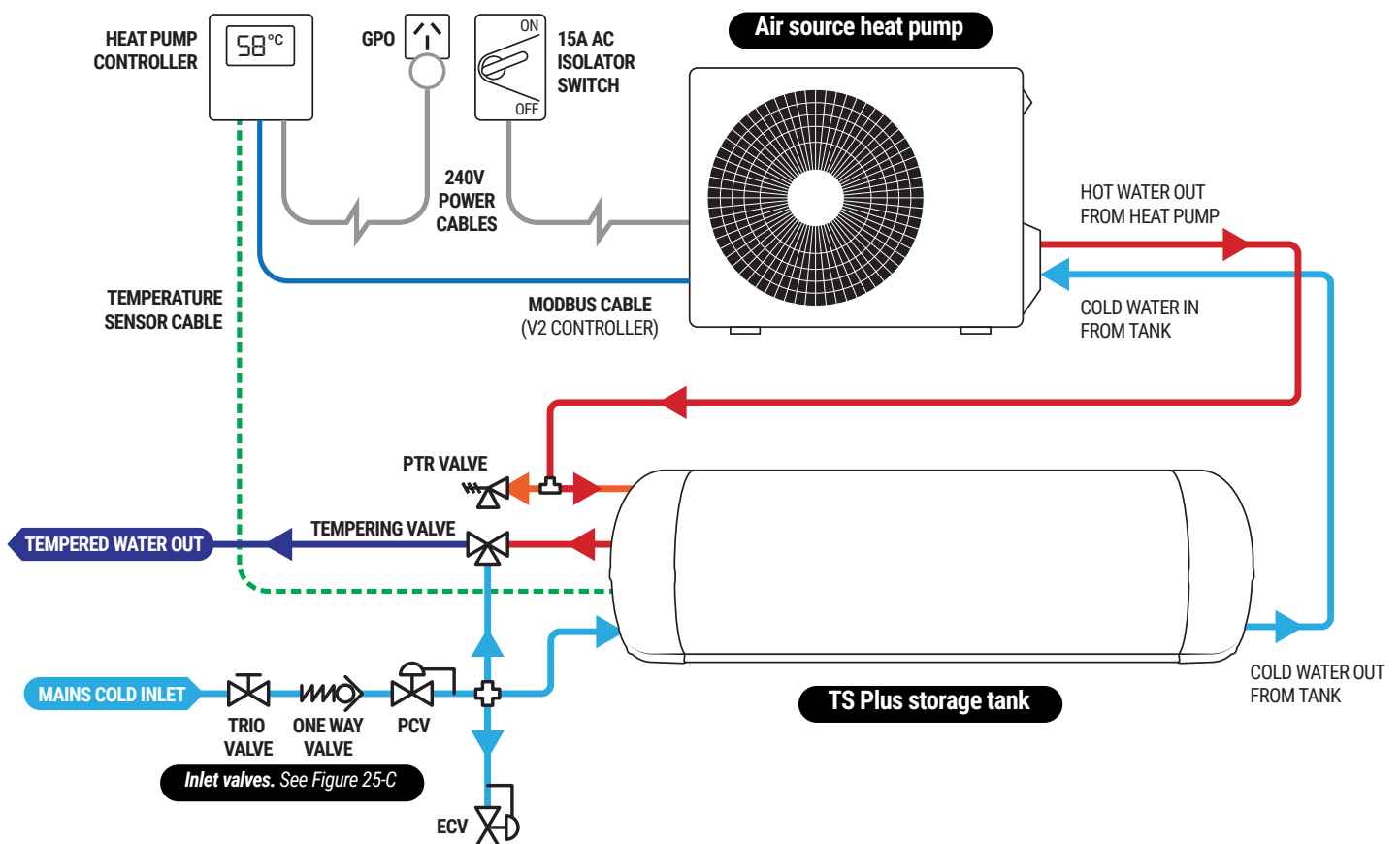
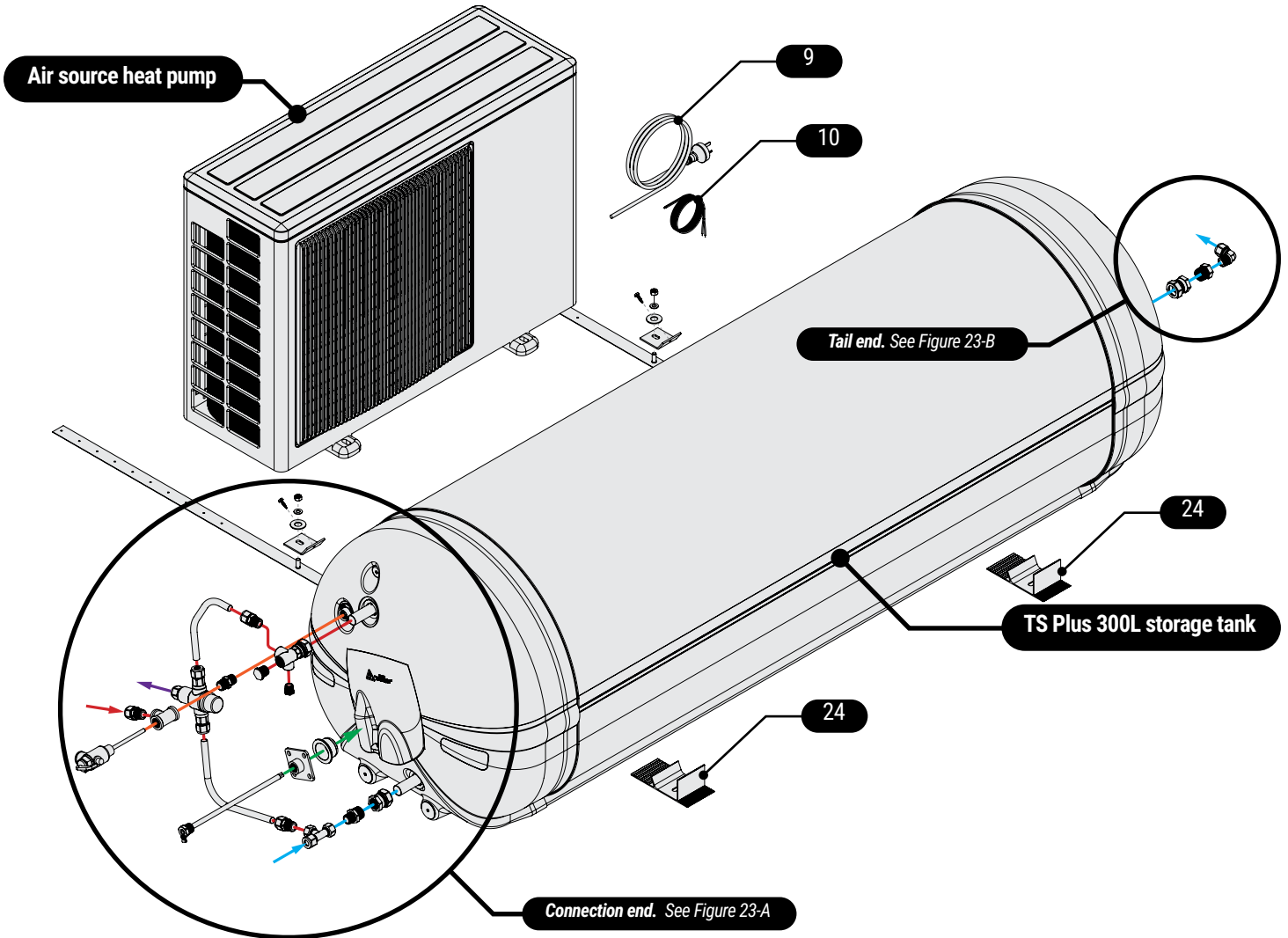

Figure 22. Heat pump wiring and plumbing connections

Figure 23. Heat pump and storage tank plumbing connections



Part	Number	Description
1	60-1003	Union, RP ³ / ₄ " - C22mm, Sub-Assembly (x2)
2	60-5065	Union, Nipple, R ¹ / ₂ " x R ¹ / ₂ "
3	60-5066	Union, DR, R ³ / ₄ " - R ¹ / ₂ "
4	60-5075	Tee, RP ¹ / ₂ "/15 x 3
5	60-5008	Bush, Reducing, R ³ / ₄ " - RP ¹ / ₂ "
6	35-8006	Seal, Element, 64mm
7	60-1209	Blanking plate, 1/2" BSP
8	60-1074	Thermowell, R ¹ / ₂ " x 280mm
9	35-3001	Plug & Cord, 10A, 2.0m
10	35-3000	Cable, 2-Core, Figure 8, 7/0.25mm, Black, 20m
11	60-1046	Union, DR Brass, R ¹ / ₂ " x C ¹ / ₂ " (x2)
12	60-1046	Union, DR Brass, R ¹ / ₂ " x C ¹ / ₂ "
13	60-1036	Elbow, DR Brass, R ¹ / ₂ " - C ¹ / ₂ ", Sub-Assembly
14	60-1043	Union, Collector Hot, 22mm, Sub-Assembly
15	60-5073	Plug, DR Brass, R ¹ / ₂ "
16	60-5074	Plug, DR Brass, R ³ / ₈ "

Part	Number	Description
17	60-5183	Pipe, TS Tempering Valve Kit, Cold
18	60-5184	Pipe, TS Tempering Valve Kit, Hot
19	60-1151	Tempering Valve, 1/2", Insulated
20	60-1188	Tee, 1/2"C x 1/2"U x 1/2"U
21	60-1138	Pressure & Temperature Valve (PTR), 700kPa
22	60-1166	Non Return Isolation/Pressure Reduction Valve (NRI-PRV) 15C
23	60-1147	Expansion Control Valve (ECV), 15/600kPa
24	60-6021	Bracket, Collect - Tank (x2)
25	60-1208	Strap, Mounting, Tank, Type A with Stud (x2)
26	60-4004	Clamp, Mounting, Tank, Type A (Solitaire) (x2)
27	75-4064	Washer, Stainless Steel, M12 (x2)
28	75-4001	Washer, Stainless Steel, M8 (x2)
29	75-4000	Nut, Hex, Stainless Steel, M8 x 1.25 (x2)
30	75-4091	Screw, Hex head, SD, Stainless Steel, 10g x 18 (x2)
*	82-825-009	Angle Support for TS Tank available (not shown)

Figure 23-A. Connection end

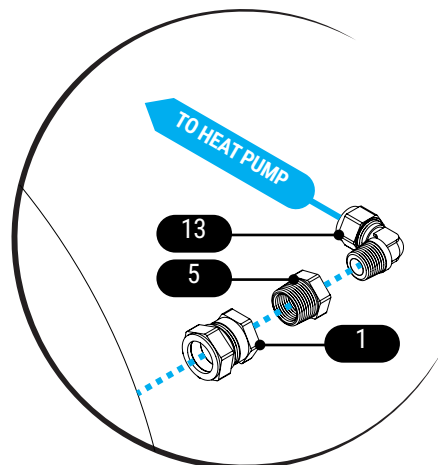
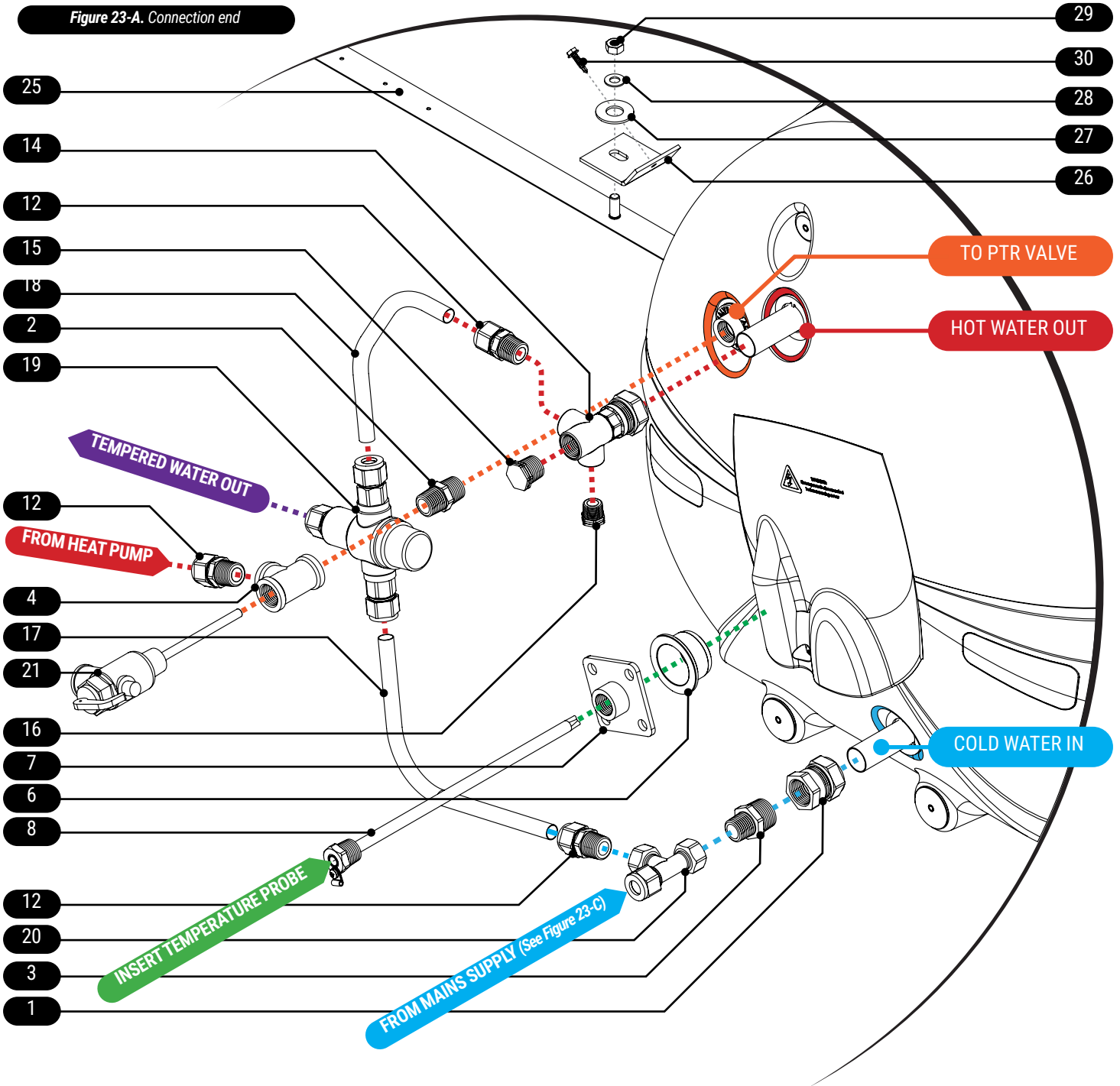

Figure 23-B. Tail end connections

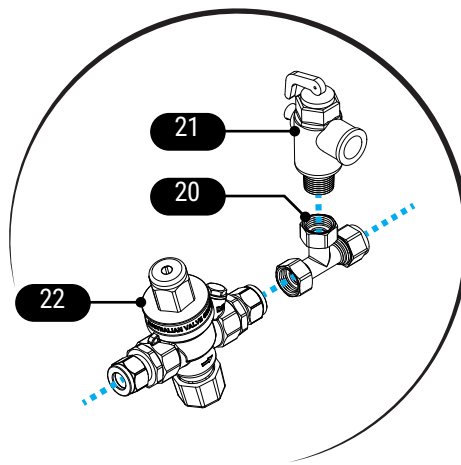

Figure 23-C. Mains supply valves

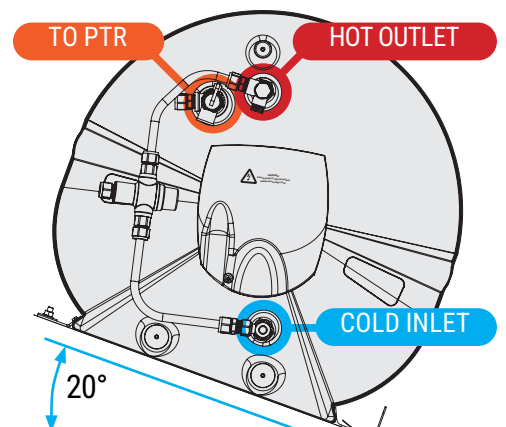

Figure 24. Tank inclination*

Mounting and securing the tank



1. Secure the tank strap to the roof rafters.
 - a. for tiled roofs, screw through the steel batten beneath the tile;
 - b. for metal roofs, screw onto the crests.
2. Hook the tank straps into the slot on the tank bracket and fold down. Position the two tank brackets under the tank foot, ensuring they are no more than 1.5m apart and between the black tank ends. Center the tank between the brackets.
3. Attach the two tank clamps behind the tank, securing them to the bolt on the tank strap with washers and a nut.
4. Finally, screw-fix the tank clamps to the tank using the provided self-drilling screws.

Installing the heat pump



5. Install the heat pump in a well-ventilated area (ground level, wall-mounted, or rooftop as per site conditions).
6. Use the provided support bracket and secure the unit with the supplied bolts, washers, and nuts.

Heat pump system wiring



WARNING

- A licensed electrician should install the system with regards to the wiring diagram provided in *Figure 22, page 17* and in accordance with local/national wiring codes. The power cord chosen must be compliant with AS/NZS 3191 and the nominal cross-sectional area should be 1.5mm² or more.
- **The heat pump must be installed on its own 15A circuit AND hardwired to a 15A isolator switch.** The controller has its own plug and must be connected to a separate general power outlet. The power point supplying the controller can be fed from the heat pump circuit.

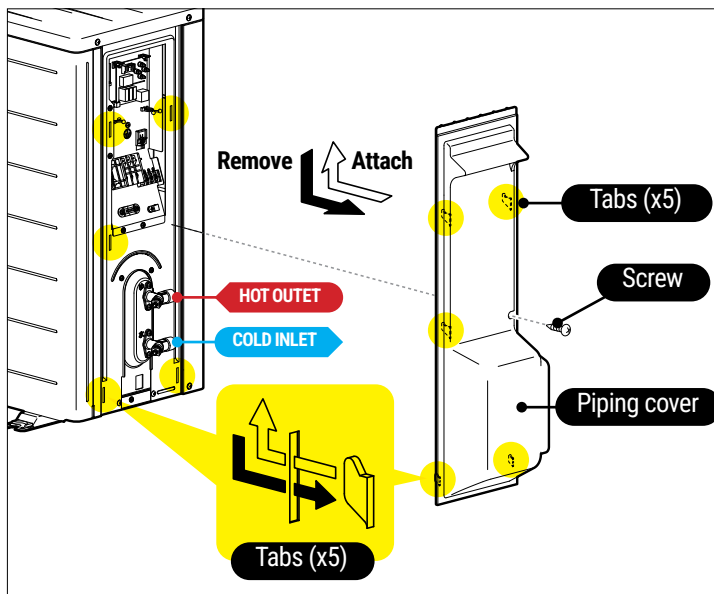

Figure 25. Heat pump piping cover

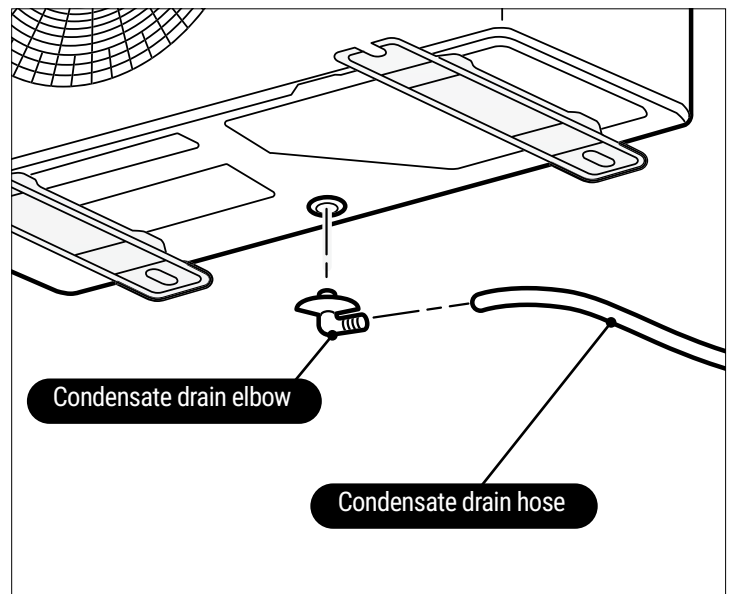

Figure 26. Heat pump condensate drain

Heat pump plumbing connections



- After removing the right-side piping cover of heat pump unit, the heat pump cold inlet and hot outlet pipes (connection ports) will be accessible as shown in *Figure 25, page 20*.
- The hot water outlet from the heat pump should be plumbed to the top port on the tank, marked PTR valve. The cold water inlet to the heat pump should be drawn from the tail end connection. It is recommended you minimise the distance of any pipe run as much as possible.
- To maximise efficiency of the thermosiphoning effect, **storage tank should be inclined at 20 degrees** as shown in *Figure 24, page 19*.



CAUTION

- There should be no valves (such as non-return valves or strainers) installed between heat pump and tank plumbing.
- The piping should have no restrictions. All hot pipes including the PTR valve must be fully insulated.
- For domestic installations, the recommended copper pipe diameter is 1/2" (12.7mm).
- PEX or other piping systems must not be used; **only copper pipe is to be used.**

Cold water supply to the tank



1. Connect the mains water supply (see *Figure 23-A, page 19*) to a Tee fitting ($1/2''C \times 1/2''U \times 1/2''U$).
2. From the Tee, connect to the cold water inlet at the bottom connection of the tank.
3. Connect the second branch of the Tee to the tempering valve cold water inlet.

Installing the temperature sensor



4. Remove the front tank cover to access the internal flange.
5. Unbolt and remove the default heating element from the flange.
6. Insert the temperature probe through the blanking plate and secure it with the provided seal.
7. Position the temperature sensor inside the probe and route it through the aperture in the tank cover.
8. Connect the sensor to the heat pump controller.
9. Reattach the tank cover securely.

Connecting the heat pump to the tank



1. Cold Water Inlet to Heat Pump (refer to *Figure 22, page 17* and *Figure 23-B, page 19*):
 - Fit a compression fitting ($22^{3/4}'' Rp$) to the tank's back cold outlet.
 - Connect an elbow fitting to the compression fitting.
 - Run insulated piping from the elbow to the bottom inlet of the heat pump $Rp 1/2''$ (marked 'Cold Water Inlet').
2. Hot Water Outlet from Heat Pump (refer to *Figure 22, page 17* and *Figure 23-C, page 19*):
 - Plumb the hot water outlet from the heat pump $Rp 1/2''$ (marked 'Hot Water Outlet').
 - Connect it to the Tee at the tank's PTR valve port.
3. Ensure all hot water pipes, including the PTR valve, are fully insulated.

PTR valve and tempering valve connections



4. Install the PTR valve onto the front face of the Tee fitting at the top-left tank port.
5. Run a relief drain line from the PTR valve to a safe drainage point.

Tank hot water outlet



6. Connect the hot water outlet at the highest point of the tank to the tempering valve.
7. The tempering valve should also receive cold water from the main supply Tee.
8. Run the mixed hot water output from the tempering valve to the household plumbing system.

Main supply valve



9. Install a non-return isolation/pressure reduction valve in line with the main supply.
10. Connect an ECV valve to a Tee before the main water enters the tank.

Heat pump electrical connections



1. The heat pump must be installed on its own 15A circuit and hardwired to a 15A isolator switch.
2. The controller has a separate plug and must be connected to a general power outlet.
3. Ensure compliance with AS/NZS 3191 wiring standards.

Post installation inspection checklist



A licensed installer should check the following before leaving the installation site.

- System check – check all connections for any leaks and check that all components are installed as per this manual.
- Take photos of all system components for warranty purposes. This should include photos of the plumbing lines to and from the tank, the heat pump and sensor port connection.
- Note down the Tank Serial Number.
- Note down the heat pump Serial Number.
- Note down the controller Serial Number.
- Fill out the Installation Record form supplied for system warranty and service issues, OR
- Submit your Installation Record via envirosun.au/warranty

SYSTEM MAINTENANCE

Envirosun solar water heaters are designed so that there is little to do in the way of system maintenance.

Personally inspecting or servicing any part of the system is not recommended.



DANGER

The operation of the thermal cutoff indicates a possibly dangerous situation. Do not reset the thermal cutoff until the water heater has been serviced by a qualified person.

Should you decide that you want to inspect the roof mounted system, it is essential that you use all safety devices required to ensure your personal safety. **Most importantly, the electricity supply must be turned OFF.**

Draining and flushing the system



CAUTION

Transfer fluid must be drained from closed circuit systems before the storage tank is drained. Failure to do so will damage the storage tank. The system must be completely drained of water before commencing any plumbing work. This will prevent damage to the storage tank in the event of a vacuum or excessive pressure forming at the storage tank.



The Envirosun TS hot water system should be drained and flushed every five years during a major service of the unit.

4. Turn off and isolate the power supply to the electrical element.
5. Turn off the water supply to the water heater.
6. Cover the collectors.
7. For closed circuit systems drain and appropriately dump the transfer fluid.
8. Release excess pressure from the tank by manually opening the Pressure & Temperature Relief valve.
9. Disconnect the cold water supply pipe connection to the tank.
10. Fit a 1/2" flexible drain pipe to the cold connection at the tank. Place the open end of the drain hose in a location where it is safe for the hot water to drain away from the tank.
11. Manually open the Pressure & Temperature Relief valve which will allow air into the tank and the water within the tank will flow out via the flexible drain pipe fitted to the cold inlet connection. Hold the valve open until the tank is empty.
12. For open circuit systems drain the collectors. Disconnect the cold pipe from the bottom left of the collector array.

Collector glass cleaning

Glass cleaning usually occurs by natural rainfall; however, if the installation is in an industrial (or similar) area with high levels of airborne particles then a qualified person can clean the collector glass with normal window cleaning chemicals and equipment. If rainwater collection occurs from the same roof on which the solar water heater is located, do not use chemical cleaning agents to clean the collectors. Any spillage of these onto the roof could cause contamination of water in the rainwater tank.

Hail damage or broken collector glass

In the unusual case that the toughened glass collector covers are broken, Envirosun does not advise replacement of the glass. The entire panel should be replaced to maintain the performance and integrity of the water heater. Replacement panels should be installed by a qualified person.

Relief valves



The lever on the relief valves should be operated at least every six months to verify it is not blocked and to remove lime deposits. Failure to do so may result in failure of the tank. If water does not discharge freely from the valves they should be checked and possibly replaced.

The relief valves and relief valve drain lines must not be blocked. Some water may discharge during each heating cycle.

Every five years all safety valves should be replaced to ensure continued life and safe operation of the system. In locations where the potable water has a Total Dissolved Solids (TDS) of greater than 600 ppm, replacement of all safety valves at 3 year intervals is recommended.

No anode

The TS Plus and THX Plus units have a 444 stainless steel inner cylinder for long life and do not require an anode for protection against corrosion.

TROUBLESHOOTING

If there is not enough hot water, we recommend that the following points are considered as part of the service call.

Low solar energy input

If there have been prolonged periods of cloud or winter is approaching it is necessary to increase the boosting time for time-clock controlled systems or to turn on the booster for systems with a booster isolation switch.

Solar collector shading

Often trees or other buildings can shade the solar collectors or there can be a dirt build-up on the glass cover. Trees should be cut back if possible or the system relocated if removal of the shading is not possible in the present location. If the glass is dirty, this should be cleaned by a qualified person with standard domestic glass cleaner. If rainwater collection occurs from the same roof on which the solar water heater is located, do not use chemical cleaning agents to clean the collectors. Any spillage of these onto the roof could cause contamination of water in the rainwater tank.

AES booster system not operating

For electric booster AES, the fuse or circuit breaker supplying the AES should be checked. If the time clock (where fitted) and the fuse or circuit breaker are operational and the water is cold, you can turn the booster isolator on and off to see if the electricity meter speed changes. If there is no change in speed, it indicates there may be a booster problem. Contact your authorised EnviroSun dealer or installation service provider as soon as possible.

For gas booster AES, the gas and electric supplies to the gas heater should be checked to ensure they are both on. If water temperature from the gas heater is below 70°C and both supplies are on and the gas heater does not ignite, there may be a problem. Contact your authorised EnviroSun dealer or installation service provider as soon as possible.

Excessive water discharge from the valves

All EnviroSun solar water heaters have two pressure valves located within the system configuration.

The cold water Expansion Control Valve (ECV), located in the cold water supply pipe, may release a small amount of water from time to time during the heating cycle of the system. Normally the discharge will be less than 10L per day but can be more depending on the water usage and temperature rise.

The PTR valve, located on the storage tank, may also release a small expansion discharge.

Hot water use higher than anticipated

Often the hot water usage of showers, washing machines and dishwashers is underestimated by the customer. Review these appliances to determine if the daily use is greater than the storage volume of the water heater. EnviroSun TS system tanks contain 300 litres of hot water, if the hot water load is greater than 300 litres within a short period of time, there may be periods where the water temperature is slightly lower than normal. It is also advisable to inspect hot water tap washers etc. for leakage and replace if necessary.

Thermosiphon Arrestor valve operation (optional)

For low loads or in high radiation areas, the solar hot water system can have a Thermosiphon Arrestor valve (TAV) installed. This valve prevents the water in the tank from overheating. It does this by stopping the thermosiphon action from moving the hot water in the collectors to the storage tank.

As a consequence of the operation of the TAV the water in the collectors can become superheated. When this occurs, opening a tap may generate some noise. This is not a problem as the system is designed to handle these conditions. The noise will stop after the tap is closed or enough hot water is used to open the TAV. This should not occur after dark.

The closing of the TAV indicates that the solar hot water system is generating more hot water than is required.

STANDARD WARRANTY

Warranty terms

This warranty is given by Energie Group Australia Pty Ltd in relation to EnviroSun® Solar Hot Water Systems (the Product).

The benefits conferred by this warranty are in addition to all other legal rights and remedies of the Customer in respect of the Product. Given installation and application is in accordance with the manufacturer's specifications and instructions, the Product and components are warranted by EnviroSun for the cost of labour and components in the event of defects arising from faulty materials and/or workmanship in accordance with the warranty conditions and exclusions stated in this document.

Where the Product is installed outside the boundaries of a Capital City Metropolitan area or where the Product is installed outside a 25km radius of a EnviroSun Dealer business address, the cost of transport, insurance and travelling will be charged to the consumer.

For all new Product purchases through public sales auctions, internet and/or other electronic sales auctions or remote offerings, the warranty for the Product is the responsibility of the dealer or reseller of the Product, and not of EnviroSun.

Warranty of the Product will remain with the Product for the warranty coverage period.

Warranty definitions

Domestic Use

Warranty periods that are allocated under "Domestic Use" are based on hot water usage patterns of a typical family, for personal hygiene use.

EnviroSun "Domestic Use" warranty periods apply to water heaters installed to supply heated water to a single-family domestic dwelling.

Commercial Use

The warranty periods that are allocated under "Commercial Use" are for all other applications other than domestic use as specified above.

Warranty conditions

The initial point of contact for all warranty claims is the EnviroSun Dealer from whom the Product was purchased.

All warranty claims must be reported to EnviroSun no later than 14 days from the date the fault is reported to the EnviroSun Dealer. All terms of this warranty are effective from the date of installation of the Product and the attending service person reserves the right to verify this date by requesting a copy of the certificate of compliance¹, installation record issued by an appropriately qualified installer or proof of purchase prior to the commencement of any warranty work.

The Product must have been installed, commissioned, serviced, repaired and removed by a licensed gasfitter or plumber in accordance with the manufacturer's installation instructions, current AS/NZS 3000, AS/NZS 3500, AS/NZS 5601, local regulations and municipal building codes by persons authorised by local regulations to do so. Cost of labour or materials to remedy an installation that does not comply with these requirements will be at the express cost of the installer.

The Product must be operated and maintained in accordance with EnviroSun's operating instructions. This warranty only applies to the Product as supplied by EnviroSun and does not apply to any additional electrical and/or plumbing parts supplied by the installer. Where the appliance has not been sited in accordance the installation instructions or installed such that normal service access is difficult, a service charge may apply. If, at the discretion of the attending service person, access with is assessed as dangerous, service will be refused.

Any work required to gain reasonable access to the appliance will be chargeable to the customer by the attending service person including, but not limited to, removal of cupboards, doors, walls, or the use of special equipment to move components to floor level.

The Product is covered for the indicated period from the date of installation. Should a part of the complete Product be replaced during this period, only the balance of the original warranty will continue to remain effective.

This warranty applies to the Product when it is connected directly to a reticulated water supply from a state approved water utility.

This warranty does not apply if the Product is connected to any alternative water supplies if the water chemistry and impurity levels of alternative water supplies exceed the limits specified in the Water Properties Table on page 6.

Examples of alternative water supplies include private bore water, water from private dams and water supplied from a reticulated water supply but where the water chemistry is deliberately altered before supplying the water heater. Should the Product be installed in a regional location where regular flushing is required due to sediment build-up, the drain cock for flushing must be fitted at the time of installation at customer expense. A warranty will apply to rain water tanks, as alternative water supply, ONLY in circumstances where rain water is filtered and free of any physical or



sediment debris and water quality does not exceed the limits specified in the Water Properties Table on page page 6.

Component manufacturers are at liberty to alter the design or construction of the components notwithstanding that the Product may have been sold by description or sample, even though alterations made have been introduced from the date of contract and the date of delivery provided that the Products are of the same or similar quality and are fit for the purposes for which they are purchased. Such alterations shall not constitute a defect in design or construction under this warranty.

Envirosun reserves the right to alter the design or construction of the Product within allowance of the relevant Standard(s), industrial and State and Territory legislation without notice. Envirosun warrants to the original purchaser, or for Product purchased from a Reseller, to the original end user, that the Product will be free from any defects in materials and workmanship from the date of shipment or invoice or, if longer, the period stated in this policy in accordance with the Warranty Coverage table on page 27.

During the warranty period, Envirosun will, at its option, apply one of the three following remedies:

- i. provide replacement parts necessary to repair the Product,
- ii. replace the Product with same Product or similar approved newer design,
- iii. refund the amount purchaser paid, LESS DEPRECIATION, upon its return.

Envirosun or a Envirosun Dealer will provide labour to resolve warranty issues during the warranty period. Repair service shall be available at the purchaser's location. Envirosun will determine how and where repair services are provided, and the purchaser may, at Envirosun's reasonable cost, be required to deliver product to an authorised location.

Replacement parts and/or Products will be new or serviceably used, comparable in function and performance to the original part or Product and warranted for the remainder of the original warranty period. Purchasing additional Products from Envirosun does not extend your warranty period.

If Envirosun requires the return of defective parts/products, the Envirosun Dealer or purchaser shall return them within 14 days of receiving replacement parts. Failure to return defective parts will attract charges for replaced parts/systems and their shipment to the Envirosun Dealer or purchaser. In addition to 12 months comprehensive warranty, Envirosun offers a warranty on tanks and collectors for the Product as shown in the Warranty Coverage tables.

Warranty coverage

Queensland, New South Wales, Victoria

Envirosun offers the following coverage from date of installation in **Queensland, New South Wales and Victoria**:

Component	Up to 2 years Parts and labour		Up to 2-10 years Parts only
TS Plus Open Circuit System			
Tank	✓	✓	✓
Collector	✓	✓	✓
Electrical components, valves and plumbing accessories	✓	✓	✗
THX Plus Closed Circuit System			
Tank	✓	✓	✓
Collector	✓	✓	✓
Expansion vessel	✓	✓	✗
Electrical components, valves and plumbing accessories	✓	✓	✗

NOTE: Without limiting the periods shown in the table, a 5-year whole-of-product warranty applies where a rebate has been received under either the Victoria Energy Upgrades program or Solar Victoria's Solar Homes Program for a water heater installed from 1 JULY 2023. Proof of receipt of the rebate is required at the time of the service call. Systems installed for commercial applications are subject to reduced warranties.

South Australia, Western Australia, Northern Territory

Envirosun offers the following coverage from date of installation in **South Australia, Western Australia and Northern Territory**:

Component	Up to 2 years Parts and labour		Up to 7 year Parts only
TS Plus Open Circuit System			
Tank	✓		✓
Collector	✓		✓
Electrical components, valves and plumbing accessories	✓		✗
THX Plus Closed Circuit System			
Tank	✓		✓
Collector	✓		✓
Expansion vessel	✓		✗
Electrical components, valves and plumbing accessories	✓		✗

NOTE: Systems installed for commercial applications are subject to reduced warranties.

Warranty is provided to Original owner/occupier only. All other owners are limited to a 5 year warranty

Nonresidential / commercial use installations are limited to 3 year warranty parts ONLY

Warranty exclusions

The following exclusions may cause the warranty to become void, and may incur a service charge and cost of parts that may be required.

1. Accidental damage, failure due to misuse, abuse and accidents.
2. Failure due to incorrect installation and/or attempts to repair the Product other than by an Envirosun Dealer or approved service personnel.
3. Failure to install, commission, service, repair and remove the Product in accordance with the manufacturer's installation instructions, current AS/NZS 3000, AS/NZS 3500, AS/NZS 5601, local regulations and municipal building codes by persons authorised to do so.
4. Failure due to use of parts other than Envirosun branded/approved parts.
5. Where the tank or piping system leaks or fails to operate normally due to frost or freezing.
6. Where the Product component has failed directly or indirectly as a result of excessive water pressure, negative pressure (partial vacuum), corrosive atmosphere, faulty plumbing and/or electrical wiring, or major variations in electrical energy supply.
7. Where the water stored in the cylinder exceeds at any time levels as detailed in this document.
8. Any serial tags/stickers on any of the components are removed or defaced.
9. The Product is relocated from its original point of installation.
10. This warranty does not cover:
 - a. claim for damage to walls, foundations, gardens, etc. or any other consequential loss or inconvenience either directly or indirectly due to leakage from the water heating system or any other matter related to the system or its operation.
 - b. the effects of sludge/sediment as a result of connection to a water supply from suitably filtered or treated sources e.g. spring, dam, bore or river.
11. Consequential damage or any incident caused by a breach of the requirements as set out in this document.
12. Our goods come with guarantees that cannot be excluded under the Australian Consumer Law. You are entitled to a replacement or refund for a major failure and for compensation for any other reasonably foreseeable loss or damage. You are also entitled to have the goods repaired or replaced if the goods fail to be of acceptable quality and the failure does not amount to a major failure.

OH&S Disclaimer

Envirosun and its Authorised Dealers work with and recommend various installation and plumbing companies to install, test and certify correct operation of solar hot water systems or the Product. Envirosun is a supplier of systems only.

Each installation must be covered by the installer's insurances, commercial terms and conditions and by the applicable OH&S legislation. Each person that installs assembles or services must comply with all OH&S requirements relevant to the type of work being conducted including, but not limited to, plumbing work, work on heights exceeding 2.5m and electrical work.

The customer must ensure that it complies with all its OH&S obligations. This warranty will be void if these conditions are not met.

CONTACT DETAILS

For further information, please call one of the following phone numbers from anywhere in Australia:

Energie Group Australia Pty Ltd	460 Victoria Road, MALAGA WA 6090	www.energiegroup.au
	Sales and Support:	1300 046 893 info@energiegroup.com.au
	For downloads and information:	www.envirosun.au

THIS PAGE INTENTIONALLY LEFT BLANK



 **1300 046 893**
Sales and Support

 **info@energiegroup.com.au**
Email

 **envirosun.au**
Downloads & Info