



Installation & Owners Manual

Envirosun® Active Split Solar Water Heater

AS250 / AS315 / AS400



INSTALLATION RECORD

PLEASE COMPLETE THIS PAGE AS A RECORD OF THE INSTALLATION DETAILS FOR YOUR REFERENCE TO DETERMINE WHEN THE SYSTEM IS DUE FOR SERVICE OR IF A WARRANTY MATTER SHOULD ARISE.
SCAN THE QR CODE WITH YOUR PHONE AND REGISTER YOUR WARRANTY ONLINE.

Energie Group
Australia Pty Ltd
ABN 50 166 500 787
460 Victoria Road
Malaga WA 6090



IMPORTANT!
REGISTER YOUR
WARRANTY



envirosun.au/warranty

.....
Owner Name

.....
Installation Address

.....
Suburb

.....
State

.....
Postcode

.....
Telephone (Home or Mobile)

.....
(Work)

.....
Email

.....
System Model Number

..... / /
Install Date

.....
Tank Serial Number

.....
Pump Module Serial Number

.....
Heat Exchanger Serial Number

.....
Collector 1 Serial Number

.....
Collector 2 Serial Number

.....
Collector 3 Serial Number

.....
Installer Name

.....
Installer Telephone

.....
Installer Email

.....
Installer Address or Business Name

.....
Comments

.....
Customer Signature

.....
Installer Signature

..... / /
Date

CONTENTS

IMPORTANT NOTES	2	Hot water connection	14
Interpretation of marks and symbols	2	Pressure & Temperature Relief (PTR) valve	14
SYSTEM OVERVIEW	2	ELECTRICAL CONNECTIONS	14
Installing your new EnviroSun AS System	2	Electrical connection for electric AES (booster).....	14
Envirosun quality	2	Electrical circuit diagram	15
System components	2	Electrical installation for the PM-602.....	15
Storage Tank.....	2	Controller setting	17
Solar Collectors	2	Power on and access Installer Mode	17
Model numbers explained	3	Verify and adjust settings	17
Potable water use only (not suitable for pool heating).....	3	Gas AES installation instructions.....	17
Cold climate installations	3	Approved gas AES models.....	18
IMPORTANT SAFETY INFORMATION	4	COMMISSIONING & HANDOVER	18
Water discharge through the pressure valve	4	Commissioning	18
Warning about hot water	4	Customer handover	18
Extended system inactivity	4	SYSTEM MAINTENANCE	18
Hydrogen gas can accumulate!	4	Draining and flushing the system.....	19
Ancillary Energy Support (AES) booster systems.....	5	Collector glass cleaning	19
Electric boosted systems.....	5	Hail damage or broken collector glass	19
Gas boosted systems	5	Relief valves	19
DIMENSIONS AND TECHNICAL DATA	6	Anode.....	19
Collector and Tank dimensions	6	TROUBLESHOOTING	20
Parts Kit details	7	Low solar energy input	20
System weights.....	7	Solar collector shading.....	20
IMPORTANT INSTALLATION INFORMATION	8	AES (booster) system not operating.....	20
Local standards.....	8	Excessive water discharge from the valves	20
Safety.....	8	Hot water use higher than anticipated	20
Water quality	8	Water discharge from the frost valve.....	20
Pressure reducing valve.....	8	Condensation in solar thermal collectors	20
High wind or cyclonic areas.....	9	WARRANTY	21
Piping material	9	Warranty terms	21
Supplementary heat sources	9	Warranty definitions.....	21
Legionella requirements	9	Domestic Use	21
Roof location selection.....	10	Commercial Use	21
❶ Collector orientation	10	Warranty conditions	21
❷ Shading	10	Notification.....	21
❸ Storage tank location.....	10	Installation.....	21
❹ Collector inclination	10	Maintenance and operation	21
❺ Roof structure.....	10	Location	21
❻ Roof area.....	10	Water connection	22
INSTALLATION INSTRUCTIONS	11	Product variations	22
Installing the collectors	11	Labour costs.....	22
Flat roof installations.....	13	Replacement parts	22
Solar flow and return lines.....	13	Warranty period	23
Connections for the PM-602.....	13	Warranty exclusions	23
PLUMBING CONNECTIONS	14	OH&S Disclaimer	24
Cold water connection.....	14	CONTACT DETAILS	24
Cold water expansion relief valve.....	14		

IMPORTANT NOTES

Interpretation of marks and symbols

Failure to follow these instructions may lead to serious malfunctions of the device and danger to the user.



Important information is highlighted with this symbol.



CAUTION

Instructions marked with this symbol indicate additional care should be taken when performing the instructed task or activity.



Instructions with this symbol relate to important installation requirements that ensure the correct operation of the device.



WARNING

Instructions marked with this symbol must be followed. Failure to do so may lead to product damage and harm to the user.

SYSTEM OVERVIEW

Installing your new EnviroSun AS System

You are installing one of the most advanced solar water heaters in the world. This manual provides you with the essential information needed to install the EnviroSun Active Solar system correctly. Please read it carefully and follow all the instructions. You will find the following information useful.

EnviroSun quality

Before you can sell in Australia, or achieve any of the State or Federal Government rebates, your product must comply with the rigorous Australian Standards for solar water heaters. Our products comply with all these standards. The Federal Government Small-scale Renewable Energy Scheme, called STCs, is an indication of solar efficiency. If you compare any of the EnviroSun products with an equal competitor model, you will find that EnviroSun systems often achieve more STCs than our competitors.

System components

The EnviroSun AS Solar Water Heater is supplied in kit form so that it can be assembled and connected in various configurations to suit the installation location and user requirements.

Typically, the kit contains the five main components of your solar water heater system. These are:

1. Potable Water Storage Tank;
2. Solar Controller Module;
3. Solar Collector(s);
4. Ancillary Energy Support (AES) System. Please note, the AES system can be either electric or gas operated dependent on the model purchased;
5. Parts Box, which includes pipes, fittings and mounting rails to interconnect and mount the system.

Storage Tank

The potable water storage tank is used to store the heated water ready for household use. It is constructed of high-quality vitreous enamel lined low carbon steel to provide long life. The tank is insulated with high-density polyurethane to ensure minimal heat losses and maximum structural strength.

Solar Collectors

The solar collector contains a multi-tube copper water way system, bonded to a solar absorber plate. This combination collects solar energy and transfers it to the fluid within the collector circuit. The absorber plate system is enclosed in an insulated aluminium casing covered with a high strength toughened glass sheet that protects the absorber system from physical damage.

Model numbers explained

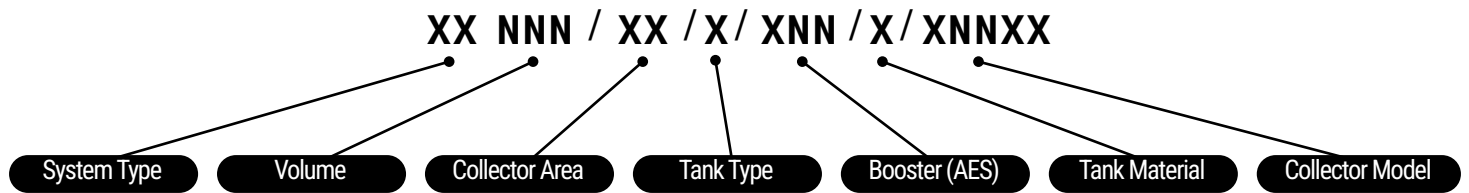

Figure 3. System model number

Variable	Categories	
System Type	AS	Active Split (pumped)
	TS	Thermosiphon
	HP	Heat Pump
Volume	250, 315, 400	Nominal Storage Volume (Litres)
Collector Area	20, 25, 40, 50, 60	Nominal Collector Area (m ² x 10)
Tank Type	O	Open Circuit
	C	Closed Circuit
Booster (AES)	E	Electric
	G	Gas
	XX	Booster Rating (kW x 10 or Lpm)
Tank Material / Designation	V	Vitreous Enamel
	S	Stainless Steel
Collector Type	E20HS, E25HS or E20HA	

Table 1. System model number

For example, given the product code **AS315/40/0/E36/V/E20HS**, we can determine the system comprises the following:

- AS** = Active Split system;
- 315** = 315 litre storage tank;
- 40** = 4m² of collector area;
- 0** = open circuit
- E36** = electric AES with 3.6 kW rating;
- V** = vitreous enamel tank;
- E20HS** = 2m² selective surface solar collector, model E20HS.

Potable water use only (not suitable for pool heating)



Envirosun AS Systems are designed for domestic and commercial potable hot water use. They are not suitable for heating pool water or other chemically treated water.

Cold climate installations



The open circuit system is not suitable for frost prone or freeze areas. Whilst frost valves may be used to protect from mild damage of frosts to collectors, installing a frost valve will not guarantee against frost damage. **Damaged sustained to the system in the event of freezing is not covered under warranty.**

If the unit is to be fitted in areas prone to frost and freezing, the unit must be installed in accordance with any relevant sustainability programme (such as the Sustainability Victoria program).



WARNING

A breach of this requirement may void the warranty in the event of damage caused by leaking due to frost or freezing.

IMPORTANT SAFETY INFORMATION

Water discharge through the pressure valve

All EnviroSun solar water heaters have two pressure valves located within the system configuration. The cold water Expansion Control valve (ECV), located in the cold water supply pipe, may release a small amount of water from time to time during the heating cycle of the system. The water discharge is water expanding due to the heating process. Normally the discharge will be less than 10 litres per day but can be more depending on the water usage and the temperature rise. The Pressure & Temperature Relief valve, located on the storage tank, may also release a small expansion discharge.

Warning about hot water

Water heaters have the ability to produce hot water very quickly. To reduce the risk of scald injury, it is recommended that a temperature control valve be fitted to the hot water supply pipework. This valve should be checked **every 6 months** to ensure its operation and settings remain correct.

Check that the Pressure & Temperature Relief (PTR) valve drain pipe is not located where it can cause damage if hot water is discharged.

WARNING ABOUT HOT WATER

Heated water can be dangerous, especially for young children and the infirm. Water temperatures above 50°C can cause severe burns instantly and may even result in death. Those most at risk are children, disabled, elderly and the infirm.

Hot water at 60°C can severely burn a child in less than half a second, at 50°C it takes five minutes.

ALWAYS

Always test the temperature of the water with your elbow before placing a child in the bath; also carefully feel water before bathing or showering yourself. Supervise children whenever they are in the bathroom. Make sure that the hot water tap is turned off tightly.

CONSIDER

Consider installing child proof tap covers or child resistant taps (both approaches will prevent a small hand being able to turn on the tap), and setting the appliance at a maximum temperature of 50°C.

NEVER

Never leave a toddler in the care of another child. They may not understand the need to have the water temperature set at a safe level.

Extended system inactivity

If the system is not to be used for a period of a week or more during the summer months it is advisable to turn off the electricity supply to the booster and if practical, cover the solar collectors.

If the solar collectors are not covered there is a possibility that the high temperature valve in the storage tank may open and disperse small amounts of hot water for a short period to reduce the storage tank temperature while you are away. This is a normal function and does not harm the system.

Hydrogen gas can accumulate!



WARNING

If the hot water system is not used for two weeks or more, a quantity of highly flammable hydrogen gas may accumulate in the water heater. To dissipate this gas safely, it is recommended that a hot tap be turned on for several minutes at a sink, basin or bath.

Do not use a dishwasher, clothes washer or other appliance. During this procedure there must be no smoking, open flame or any other electrical appliance operating nearby. If hydrogen is discharged through the tap, it will probably make an unusual noise as with air escaping. Do not place hands or any part of your body beneath the tap during this procedure.

Ancillary Energy Support (AES) booster systems

The AES is used to heat part of the stored water on those occasions when there is reduced solar activity, for example on cloudy days. The two options for an AES are electric boosting or gas boosting.

Electric boosted systems

The electric element within the storage tank is used for the electric AES. This element is automatically controlled by an internal thermostat which only allows the electric element to operate if the water temperature in the storage tank falls below 60°C. Even then, it will only consume electricity until the water temperature is increased to 60°C. At this stage it turns off automatically.

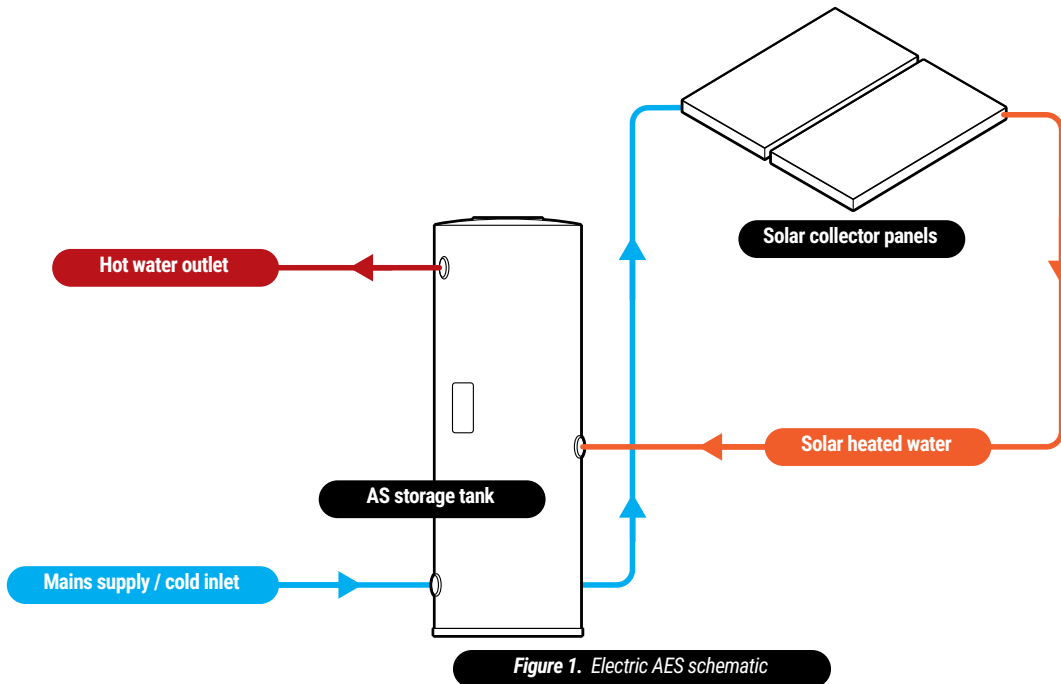

Gas boosted systems

In gas AES systems, the storage tank's electric element is disconnected. A continuous flow gas water heater, installed in series with the tank and household hot water pipes, monitors the tank's water temperature. If below 70°C, the gas heater boosts it to at least 70°C; if above, it remains off. Consult your gas heater manual for details.

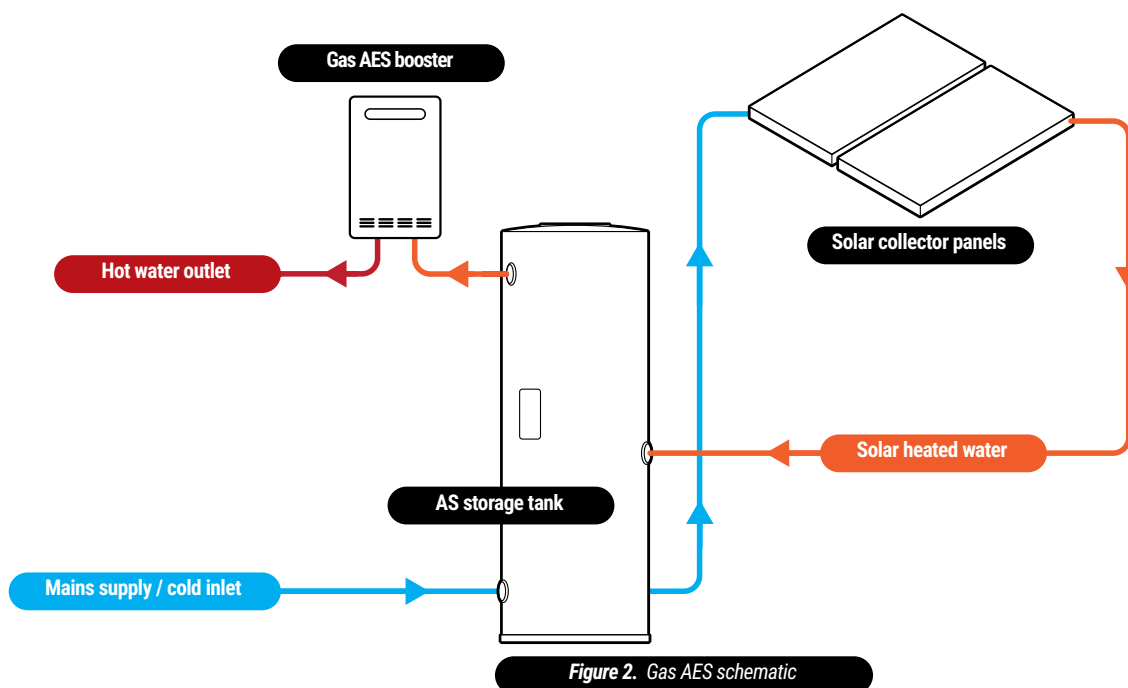

DIMENSIONS AND TECHNICAL DATA

Collector and Tank dimensions

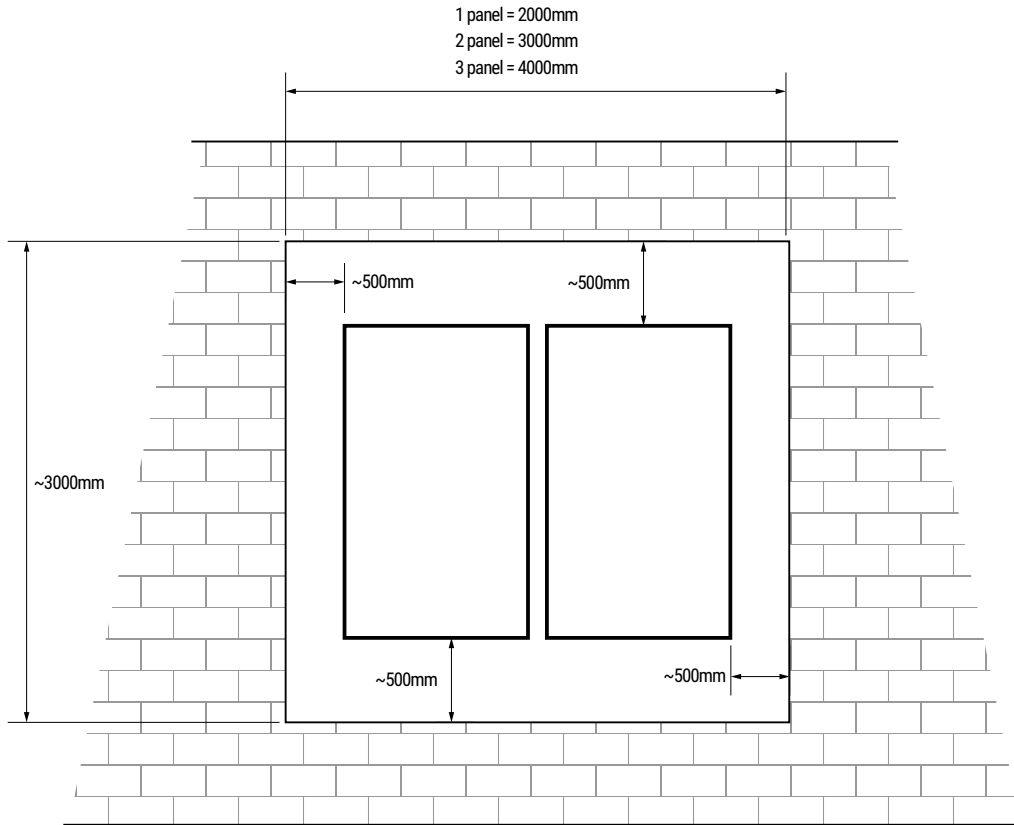

Figure 5. Collector installation area

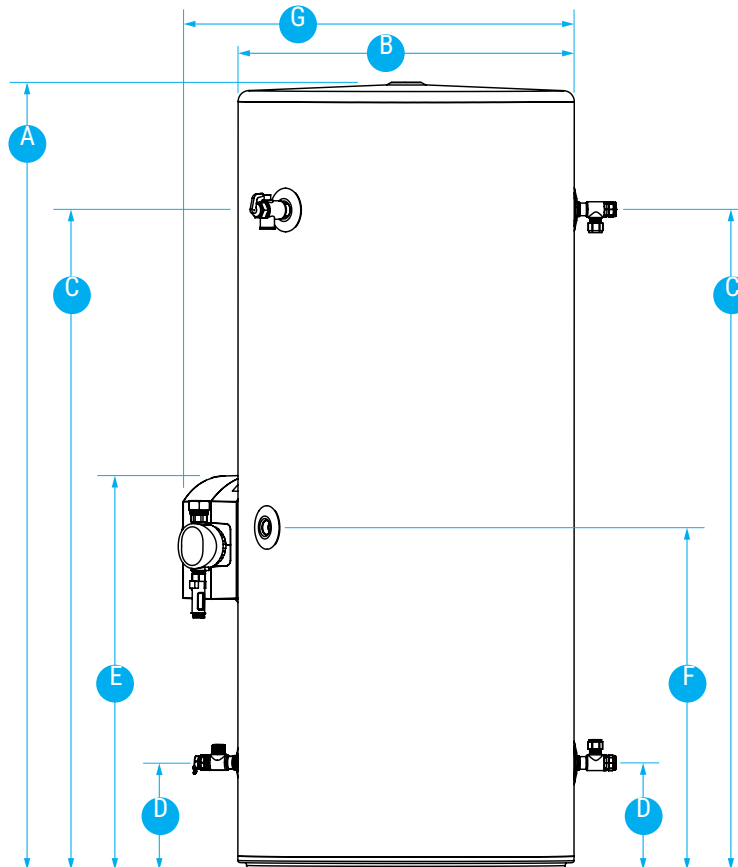

Figure 6. Tank and pump module

Model Number	Dimensions (mm)						
	A	B	C	D	E	F	G
AS315/25/O/*E25HS	1754	617	1521	195	695	838	716
AS315/40/O/*E20HS	1754	617	1521	195	695	838	716
AS315/40/O/*E20HA	1754	617	1521	195	695	838	716
AS315/50/O/*E25HS	1754	617	1521	195	695	838	716
AS400/40/O/*E20HS	1703	705	1445	219	719	642	804
AS400/40/O/*E20HA	1703	705	1445	219	719	642	804
AS400/50/O/*E25HS	1703	705	1445	219	719	642	804
AS400/60/O/*E20HS	1703	705	1445	219	719	642	804
AS400/60/O/*E20HA	1703	705	1445	219	719	642	804

Table 3. System dimensions

Parts Kit details

Note: All systems require a Pump Module (PM-602).

Model Number	Tank	Collector	Connection Kit	Mounting Kit
AS315/25/O/*E25HS	VE315/E24/V	E25HS	PK-3052	PK-1104
AS315/40/O/*E20HS	VE315/E24/V	E20HS	PK-3052	PK-1401
AS315/40/O/*E20HA	VE315/E24/V	E20HA	PK-3052	PK-1401
AS315/50/O/*E25HS	VE315/E24/V	E25HS	PK-3052	PK-1402
AS400/40/O/*E20HS	VE400/E24/V	E20HS	PK-3052	PK-1401
AS400/40/O/*E20HA	VE400/E24/V	E20HA	PK-3052	PK-1401
AS400/50/O/*E25HS	VE400/E24/V	E25HS	PK-3052	PK-1402
AS400/60/O/*E20HS	VE400/E24/V	E20HS	PK-3052	PK-1401, PK-1403
AS400/60/O/*E20HA	VE400/E24/V	E20HA	PK-3052	PK-1401, PK-1403

Table 4. Details of system parts kits



Before starting the installation, please check carefully to ensure all items are accounted for.

System weights

Tank	Material	Weight – Empty (kg)	Weight – Full (kg)
VE315/E24/V	Vitreous Enamel Mild Steel	105	439
VE400/E24/V	Vitreous Enamel Mild Steel	116	541

Table 5-A. AS tank weights

Collector	Weight – Empty (kg)	Weight – Full (kg)
E20HS	27.5	29.2
E25HS	32.5	34.5
E20HA	27.5	29.2

Table 5-B. Collector weights

IMPORTANT INSTALLATION INFORMATION

Local standards

The following standards and regulations must be taken into account when planning the installation of the Envirosun AS solar water heater system.

- AS/NZS 3500.4.2 National plumbing and drainage code hot water supply systems – acceptable solutions.
- HB 263-2004 heated water systems plumbing industry commission.
- AS/NZS 3000 Electrical installations (known as the Australian/New Zealand wiring rules).
- Any local regulations that govern this type of installation.
- This product conforms with the lead-free requirements of the National Construction Code Volume 3, PCA.

Where these instructions and any local regulations are in conflict, the local regulations shall prevail.

Safety

Do not commence any aspect of this installation until you have satisfied yourself that all safety issues have been addressed.



WARNING

This installation should only be performed by an approved professional with suitable experience and licenses, authorised by Envirosun to conduct the work.

It is imperative that installers adhere to Occupational Health and Safety Guidelines at all times. The installer is responsible for their safety and the safety of those around them.

Water quality

Water supply from an unfiltered water source that may be highly conductive or have a high mineral content may void the system warranty.

Therefore, to ensure water quality guidelines are met, the following characteristics should not be exceeded.

Water Properties	Acceptable Levels
Total hardness	200 mg/litre or ppm
Total Dissolved Solids (TDS)	600 mg/litre or ppm 250 mg/litre or ppm
Chloride	10 mg/litre or ppm 150 mg/litre or ppm
Magnesium	Min 6.5 to Max 8 .5
Sodium	850 µS/cm
pH	Min 6.5 to Max 8 .5
Electrical conductivity	850 µS/cm

Table 2. Water quality requirements

In areas of poor water quality, it is recommended that a softener, conditioner or similar device be fitted to the water supply.



WARNING

A breach of this condition may void the warranty in the event of damage caused by water quality exceeding these characteristics.

Pressure reducing valve

Where the mains water supply pressure is likely to exceed 550kPa at any time, a 500kPa pressure reducing valve that complies with AS 1357 must be fitted to the inlet of the hot water system.

This is essential to safeguard the appliance and ensure correct operation.



WARNING

A breach of this requirement may void the warranty in the event of damage caused by excessive pressure.

High wind or cyclonic areas

The standard mounting system is sufficient for mounting most standard roof installations of either metal or tile roof construction. It may be necessary to use the cyclone mounting system if one of the following applies:

- The collector must be installed 1m (recommended) to 0.5m (minimum) of a roof edge or peak.
- The installation has minimal shielding from surrounding buildings and trees, or is located on a hill or similar locations that may cause high wind effects (refer to Terrain Categories, Topographic Effects & Shielding Factors in AS 1170.2:2002, or consult a structural engineer).
- The installation is on a roof with a pitch greater than 30°.



If the solar water heater is installed in an area classed as Cyclone Region C or D according to AS 1170.2:2002, the standard mounting systems must not be used.

WARNING

Please consult a structural engineer for advice on ensuring the installation complies with local building codes and regulations.

Piping material



CAUTION

Envirosun recommends the use of copper pipe, certified to AS 1432 Class C, for use in the flow and return lines to the solar water system. **Plastic piping is not to be used for any portion of the water heater system plumbing unless the pipe manufacturer has rated it for temperatures up to 99°C and a minimum water pressure of 600kPa at these temperatures.**

Supplementary heat sources

If a supplementary heat source is connected to the storage tank, the maximum energy input cannot be more than 10 kW, including the electrical element. Where greater input is required, a pressure and temperature relief valve with a higher kW rating is to be fitted to the storage tank.

Where stove coils are used for supplementary heating, the water must be connected in an open vented manner. Refer to Australian Standard AS 3500 for more details on acceptable connection solutions.

Any supplementary heat source must be limited such that the maximum tank temperature is 80°C.

Legionella requirements

The Australian Standards require that a water heater system provide a means to inhibit the growth of the Legionella bacteria in potable water.

If the system is installed with an approved gas AES, with the outlet temperature set to 70°C, then this requirement is satisfied.

If the system is installed with an Electric AES, then one of the following requirements must be met:

1. At least 45% of the storage volume is heated to 60°C daily. This can be achieved by leaving the AES permanently on.
2. At least 90% of the storage volume is heated to 60°C for 32 minutes in each 7 day period. This will require any timing device or manual control to be adequately set-up or operated.

Roof location selection

There are six major factors to consider when selecting the solar collector installation location:

1 Collector orientation

For optimum performance, the solar collectors need to face the equator (in southern hemisphere this is north and in the northern hemisphere this is south). Installations orientated at angles of up to 45° away from the equator do not have a major effect on the annual solar output. Consequently, roof locations which face less than 45° away from the equator are acceptable. If the collectors are installed with an east facing bias the best solar input is achieved in the morning and if there is a west facing bias the best solar input is in the afternoon.

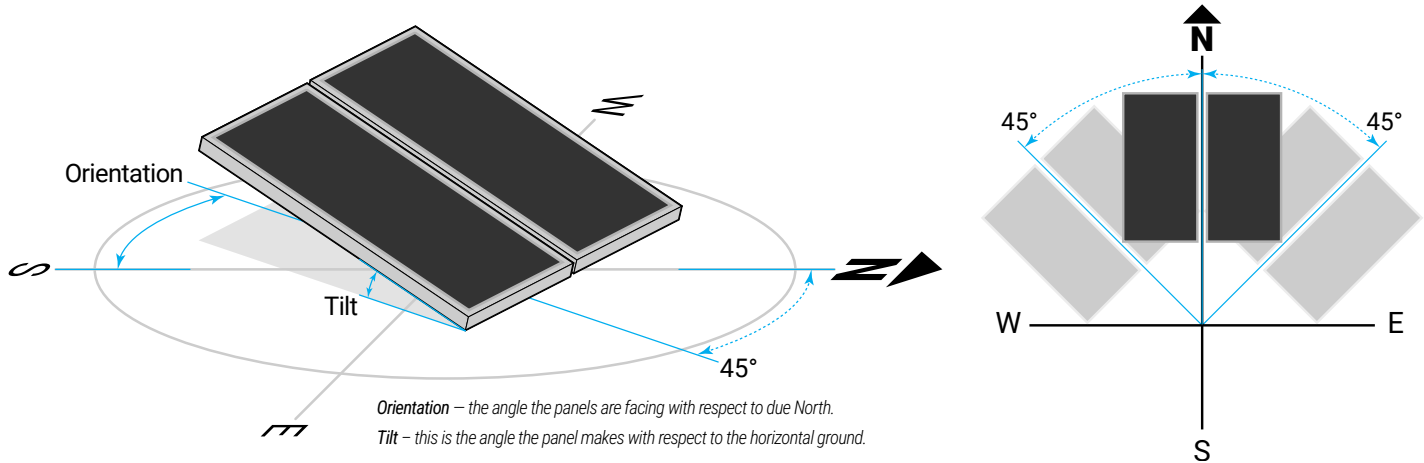

Figure 4. Collector orientation

2 Shading

Careful site inspection is required to ensure the selected location is not subjected to shading from adjacent trees or buildings throughout the day, but particularly between 9am and 3pm, the highest solar input times. Shadows are longer in winter than in summer so a site that is free of shadows from adjacent objects in summer may have some shadows in winter.

3 Storage tank location

The solar water heater should be located as close as possible to the location which uses the most hot water e.g. the bathroom or kitchen. This is to reduce energy losses which may occur if the pipe work between the solar water heater and the point of usage is too long.

4 Collector inclination

To achieve optimum performance the solar water heater should be installed on a roof pitch of greater than 10° and less than 30°. Installations on a roof where the roof pitch is greater than 30° will require additional support. If the roof pitch is less than 10°, the system will require a mounting frame to increase the pitch above 10°. Air can accumulate in installations below 10° and may not circulate effectively. Additionally the collector glass will not self-clean during rainy periods.

5 Roof structure

Ensure the roofing material and roof structure are capable of supporting the full load of the collectors and trades personnel during installation. The structure should be capable of supporting a 250kg point load. If this is not the case, additional bracing must be installed before proceeding with the installation.

The Envirosun AS hot water system can be installed on metal or tile roofs.

6 Roof area

To ensure adequate working access for the installation and future maintenance, an area of not less than 500mm should be left completely around the system. The system should be located 1m from all roof edges and peaks, with a minimum distance of 0.5m.

Sufficient distance must be allowed up the roof from the collectors for securing the mounting straps.

INSTALLATION INSTRUCTIONS



Before commencing the installation of the solar water heater system, please ensure you have familiarised yourself with the **IMPORTANT INSTALLATION INFORMATION, page 8**. Carefully remove all packaging and protective coatings and dispose of them in an appropriate manner. This includes the plastic core-strip from the back of the collector when mounted on a pitch frame, the plugs from the collector and storage tank connection pipes.

Installing the collectors

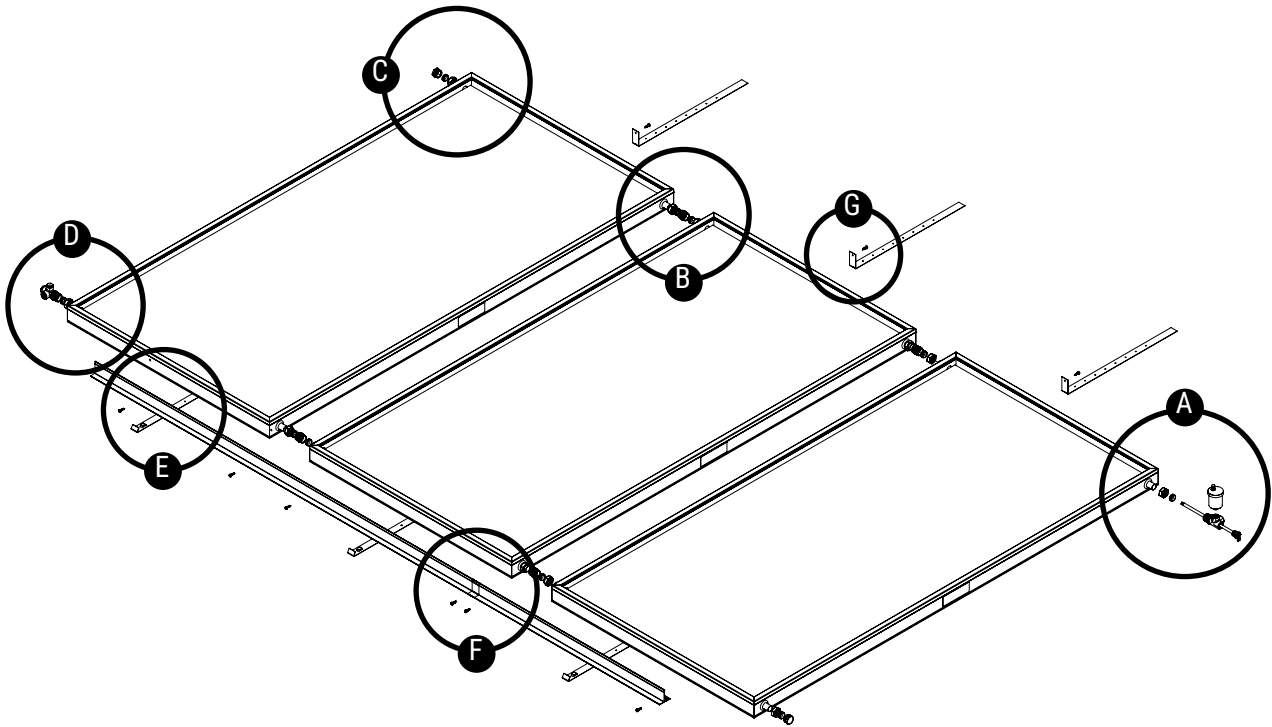

Figure 7. Solar collector panel installation

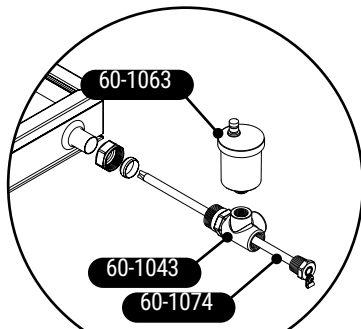

Figure 7-A. Detail A

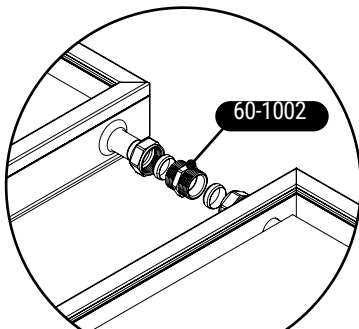

Figure 7-B. Detail B

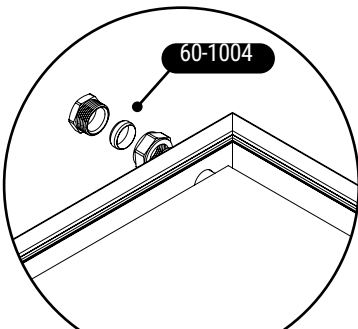

Figure 7-C. Detail C

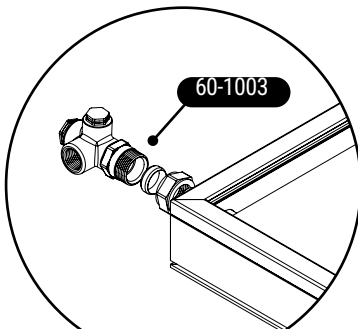

Figure 7-D. Detail D

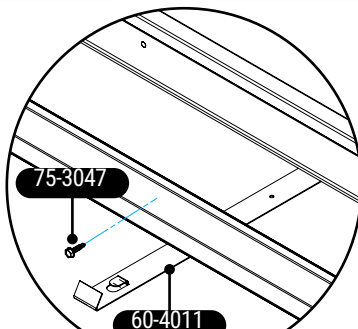

Figure 7-E. Detail E

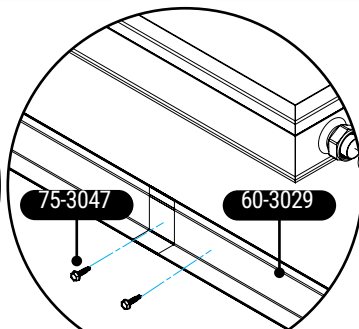

Figure 7-F. Detail F

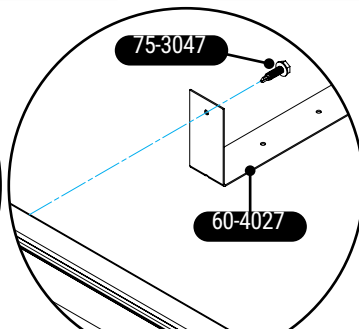

Figure 7-G. Detail G

1. Mark a point for the bottom left corner of the collector installation. This point should be at least 500 mm up from the roof edge and 500mm to the side of any obstruction or roof edge.
2. Place one end of the collector mounting rail adjacent the location marked in step 1, and laid horizontally across the roof to the right.
3. Locate two roof trusses which are under the collector mounting rail (as near as possible to the outer edges of the rail). Clip two collector straps (see *Figure 7-E, page 11, 60-4011*) to the collector mounting rail where the trusses pass under the mounting rail.
4. Adjust the mounting rail so that it is 15-20mm higher (up the roof) on the right side, then screw the collector straps to the roof trusses using the pre-punched holes.
5. Take the first solar collector and place it on the collector mounting rail, at the leftmost end.

For a single collector installation, go directly to Step 9.

6. Loosely fit two collector connectors (see *Figure 7-B, page 11, 60-1002*) to the two copper tube spigots on the right side of collector.
7. Take the second collector and place it onto the right hand side of the collector mounting rail. Now, slide collector toward the first collector until the two copper tube spigots of that collector slide fully home into the collector connectors already fitted to collector. Tighten the compression nuts of the collector connector fittings (see *Figure 7-B, page 11, 60-1002*), taking care not to twist the copper tubes of the collector. Make sure you use correctly sized spanners and that the centre nut is held steady whilst the compressing nuts are tightened.
8. Move the collectors so that they are centrally located on the collector mounting rail.
9. Fix the collector rail to the collector/s using the screws supplied. (see *Figure 7-E, page 11, 75-3047*)
10. To fix the top of the collectors to the roof, take the remaining mounting straps (see *Figure 7-G, page 11, 60-4027*) and place as centrally as possible at the top of each of the collectors with the strap fixing ends pointing up the roof.
11. Fix the collector straps to the collector using the screws supplied. (see *Figure 7-G, page 11, 75-3047*)
12. Finally, fix the collector straps to the roof rafters to complete the collector mounting.

Steps 14 to 18 relate only to the 3-Panel Array:

13. Loosely fit the two collector connectors (see *Figure 7-B, page 11, 60-1002*) to the two copper tube spigots on the right side of the second collector.
14. Locate a roof truss which is under the third panel extension rail (see *Figure 7-F, page 11, 60-3029*), as near as possible to the outer edge of the rail. Clip one collector strap (see *Figure 7-E, page 11, 60-4011*) to the extension rail where the truss will pass under the extension rail.
15. Fix the extension rail to the two-panel collector rail already installed, using the self-drilling screws supplied (see *Figure 7-F, page 11, 75-3047*). The extension rail is provided with grooves and pilot holes for correct positioning.
16. Take the third collector and place it onto the right hand side of the extension rail.
17. Slide the collector toward the second collector until the two copper tube spigots of that collector slide fully home into the collector connectors.
18. Tighten the compression nuts of the collector connector fittings (see *Figure 7-B, page 11, 60-1002*) taking care not to twist the copper tubes of the collector. Make sure you use correctly sized spanners and that the centre nut is held steady whilst the compressing nuts are tightened.
19. Slide a Compression Plug assembly (see *Figure 7-C, page 11, 60-1004*) to the top left and bottom right corners of the array. Tighten the assembly taking care not to twist the copper tubes of the collector. Make sure you use correctly sized spanners and that the nut is held steady whilst the compressing plug is tightened.
20. Assemble and install the Hot Connection Union assembly (see *Figure 7-A, page 11*) as follows;
21. Take the temperature well (see *Figure 7-A, page 11, 60-1074*) and slide it onto the copper spigot at the top right of the collector array. Tighten the assembly taking care not to twist the copper tubes of the collector. Make sure you use correctly sized spanners and that the nut is held steady whilst the compressing plug is tightened.
22. Wind five turns of thread tape onto the 1/2" BSP thread of the Temperature Well
23. Insert the Temperature Well into the 1/2" BSP socket end of the Hot Connection Union (see *Figure 7-C, page 11, 60-1043*) and tighten normally. Take care not to over tighten.
24. Wind five turns of thread tape onto the 3/8" BSP thread of the Air Bleed Valve.
25. Screw fit the Air Bleed Valve (see *Figure 7-A, page 11, 60-1063*) into the top 3/8" BSP socket and tighten
26. Open the Air Bleed Valve by turning the knob on top anti-clockwise 1½ turns from closed.
27. Connect the hot return pipe using the 1/2" BSP socket on the side fo the Hot Connection Union assembly. The piping must not be higher than the Air Bleed Valve at any point and must have a continuous fall to the tank.
28. Slide the 3/4" BSP Compression Union Assembly (see *Figure 7-D, page 11, 60-1003*) to the bottom left hand corner connection of the array. Tighten the assembly taking care not to twist the copper tubes of the collector. Make sure you use correctly sized spanners and that the nut is held steady whilst the compressing union is tightened.

The collector array is now completed and ready for connection to the water heater system.

Flat roof installations

For flat roof installations a special mounting frame is required. Once the frame is mounted, follow the instructions as outlined above.

Solar flow and return lines

To complete the solar collector array installation, 2x 1/2" (15mm) copper tubes with a minimum of 15mm of UV stable insulation and R value of at least 0.66 (such as Armaflex Solar UT tube) and 1x 2-core cable (supplied with the pump module) is to be run from the solar collector array to the storage tank location.

1. Connect one 1/2" insulated copper tube to the bottom left hand corner of the array and run down to the ground mounted storage tank location. This tube is known as the Collector Cold Connection.
2. Connect the second 1/2" insulated copper tube to the Hot Connection assembly at the top right hand corner connection of the array and run down to the ground mounted storage tank location. This tube is known as the Collector Hot Connection.
3. Connect a 2-core cable to the two wires of the black insulated temperature sensor supplied with the Pump Module (PM-602). Fully insert the temperature sensor into the thermowell of the hot connection union assembly. Secure in place with the P-Clip and screw provided. Run the cable down to the ground mounted storage tank location. This sensor is known as the Collector Temperature Sensor.



WARNING

Care must be taken to ensure that all roof penetrations are sealed to prevent water ingress and to comply with all local regulations.

CONNECTIONS AT THE STORAGE TANK

Connections for the PM-602

1. Apply thread tape or a suitable sealant to the thread of a 3/4" BSP to 1/2" compression union. Screw the union into the top (outlet) socket on the right side of the storage tank. Fasten the Collector Hot Connection (see *Solar flow and return lines*, page 13) into the compression union.
2. Apply thread tape or a suitable sealant to the threads of the 1/2"x1/2"x3/4" BSP brass tee (60-5185) and screw into the bottom (inlet) socket, on the right side of the storage tank and position the branch facing upwards.
3. Apply thread tape or a suitable sealant to the thread of the thermowell (60-1163) and screw into the brass tee.
4. Take the PM-602 module and fasten a Gland Union (60-1032) to the Check Valve (35-8009) on the upper pump fitting.
5. Install the inline flow meter (60-5171) on the inlet side of the pump.

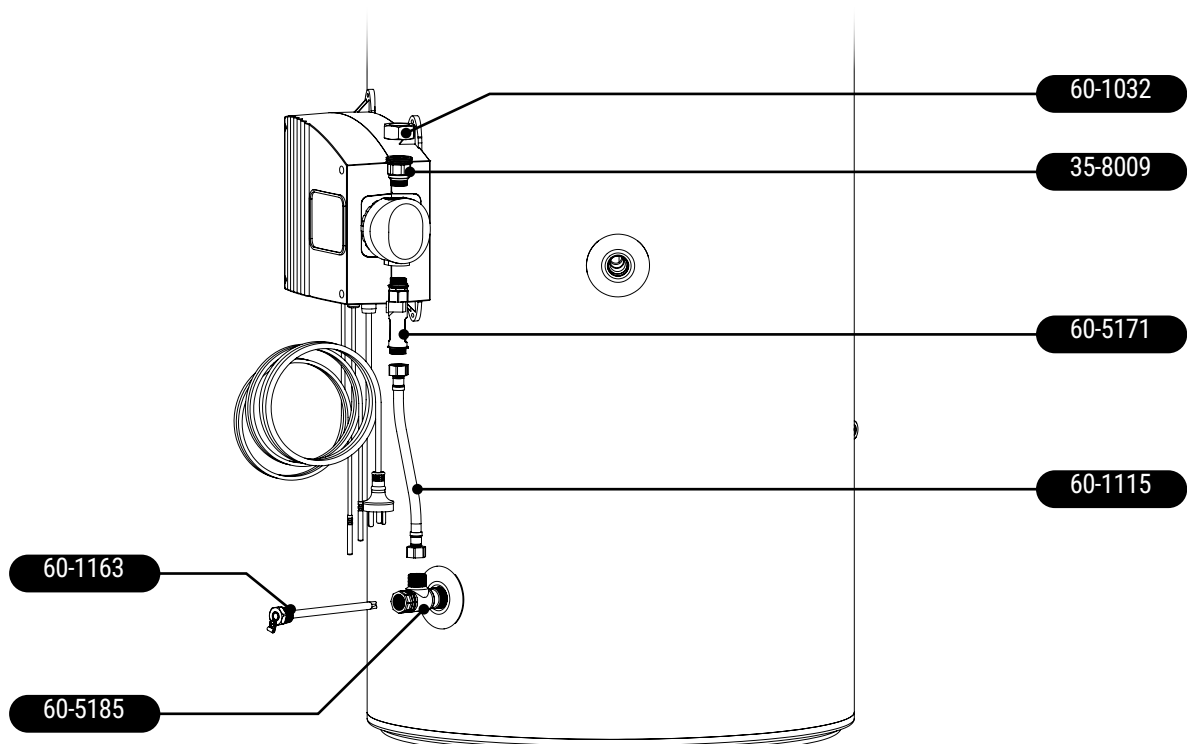

Figure 8. Connection for the PM-602

- Loosely attach one end of the 225mm Flexible Connector (60-1115) to the flow meter (60-5171), on the PM-602 module. Loosely attach the other end to the branch fitting of the tee piece at the bottom of the storage tank.
- With the flexible connector loosely fitted, move the pump module into position on the storage tank and fix in place with the self-drilling screws supplied (75-3047). Ensure the flexible connector is not kinked in any way, and the pump module is vertical. Tighten the loose nuts on the flexible connector.
- Make the Collector Cold Connection (see step 2, *Solar flow and return lines, page 13*) to the upper pump fitting of the PM-602 module.
- Open the ball valve on the flow meter by turning the screw slot until it is vertical. Set the flowrate as per *Table 7, page 18*.
- Turn on the mains water supply to the unit and fill the storage tank as normal. Check for leaks in the system and fix as required.

PLUMBING CONNECTIONS

The Storage Tank is installed and connected to the plumbing installation as normal and detailed in the Envirosun installation instructions supplied with the water heater. The household plumbing connections should be made to the tank socket fittings on the left side of the storage tank. This leaves the right side fittings free for connection to the solar collector system.

Cold water connection

A check valve and a stop cock must be fitted to the cold water supply pipe work.

- The cold water connection is made at the connection marked "Cold Water Inlet".
- Where the water supply pressure is greater than or likely to exceed 550 kPa at any time, a 500 kPa pressure reducing valve must be fitted to limit the supply pressure.



WARNING

A breach of this requirement may void the warranty in the event of damage caused by excessive pressure.

Cold water expansion relief valve

Fit the 600kPa expansion control valve, supplied in the Parts Box, in the cold water supply pipe after the check valve, stop cock and (if required) pressure reducing valve.

Hot water connection

Connect the hot water supply to the storage tank $\frac{3}{4}$ " BSP outlet connection located on the left hand side of the tank near the top. This socket will be marked "Outlet".

Pressure & Temperature Relief (PTR) valve



CAUTION

This valve can discharge very hot water, so carefully consider its location. Never discharge onto a solid surface like concrete.



The Envirosun AS hot water system should be drained and flushed every five years during a major service of the unit.

- Fit the pressure & temperature relief valve supplied with the tank into the tank socket, marked "Valve".
- Ensure that the drain line from the pressure and temperature relief has a continuous downslope and falls away from the valve and towards the ground level to a safe location, terminating above the ground level. Please ensure that the drain is installed in a place where it cannot be affected by freezing conditions (per AS 3500).

ELECTRICAL CONNECTIONS

Electrical connection for electric AES (booster)

For safe performance this water heater is fitted with a thermostat and an over temperature cut-out. These devices should not be tampered with or removed.



WARNING

Do not operate this water heater without the electrical thermostat and over temperature cut-out in the circuit.

The electric element is only connected in models using an electric AES system. No connection is made to the electric element for gas AES systems.

The electrical booster requires a 220-250 Volt single-phase AC power supply with a capacity suitable for the kilowatt rating of the element selected for the application. For example, a 2.4 kW element requires a 10 Amp supply capacity; a 3.6 kW element requires 15 Amp supply capacity.

Electrical entry for the electric AES is achieved via a 20mm opening adjacent the element surround.

A cable gland with orange circular cable, or 19mm conduit with 3 core TPS cable must be used to make electrical supply to the unit.





WARNING

The power supply must be protected by an individual fuse or circuit breaker rated to suit the booster size.

The supply to the solar water heater can be operated directly from the switchboard or via a remotely mounted switch or time clock as requested by the customer. The correct alternative should be established with the EnviroSun dealer prior to installation.

A means for disconnection (e.g. isolator) must be included in the fixed wiring to the solar water heater at the storage tank in accordance with the wiring rules.

Final electrical connection at the solar water heater is as follows:

-  **EARTH** (green/yellow) – connected to the earthing stud marked with E or the earth \perp symbol;
-  **ACTIVE** (brown/red) – connected to the terminal block position marked A or Active;
-  **NEUTRAL** (blue/black) – connected to the terminal block position marked N or Neutral.



WARNING

Do not turn on the power supply until the solar water heater has been filled with water and pressurised. There is a risk of damage to the system if the installation sequence is not followed.

Electrical circuit diagram

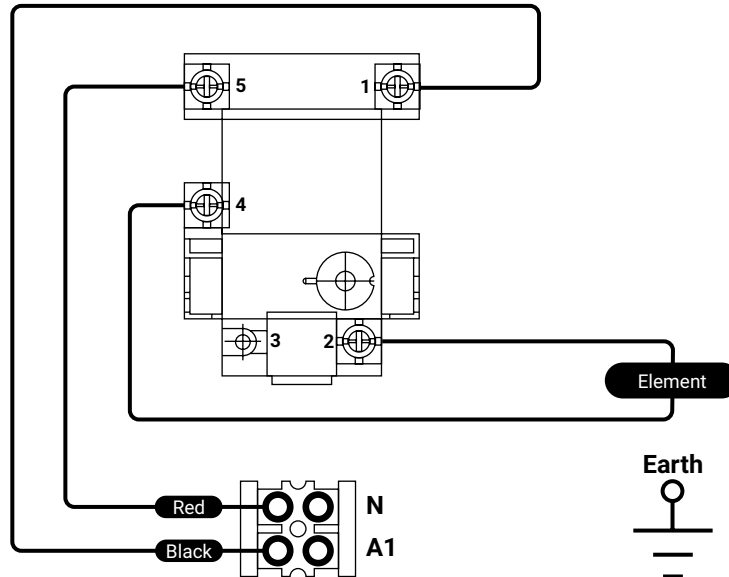

Figure 9. Electrical circuit diagram

Electrical installation for the PM-602



From the mains electrical connection, install a permanent 220-250V~, 50Hz external GPO in a suitable position near the pump module. The pump module draws a maximum 22 Watts at full load.

The temperature sensors should not be in direct contact with fluid. Always use immersion sleeves. Take the collector temperature sensor cable assembly and attach to the panel-mounted, 2-way connector. This plug will only fit one way. The tank temperature sensor cable is hard wired to the module, and exits the case through an M12 cable gland. Should extra cable length be required, there is slack inside the module. Remove the cover, loosen the cable gland, and pull through extra cord as required. Re-tighten cable gland and replace cover.

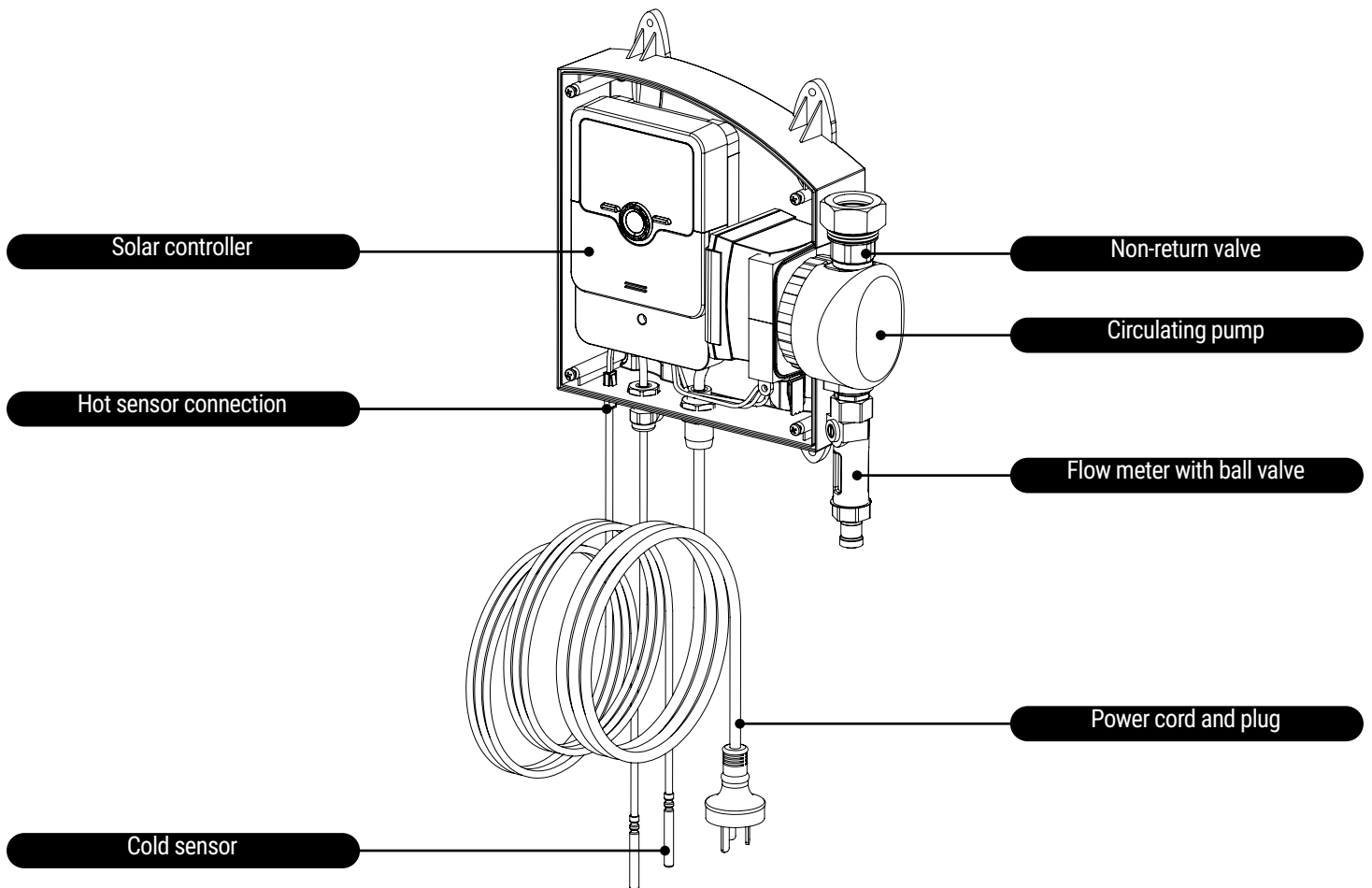

Figure 10. PM-602 general arrangement

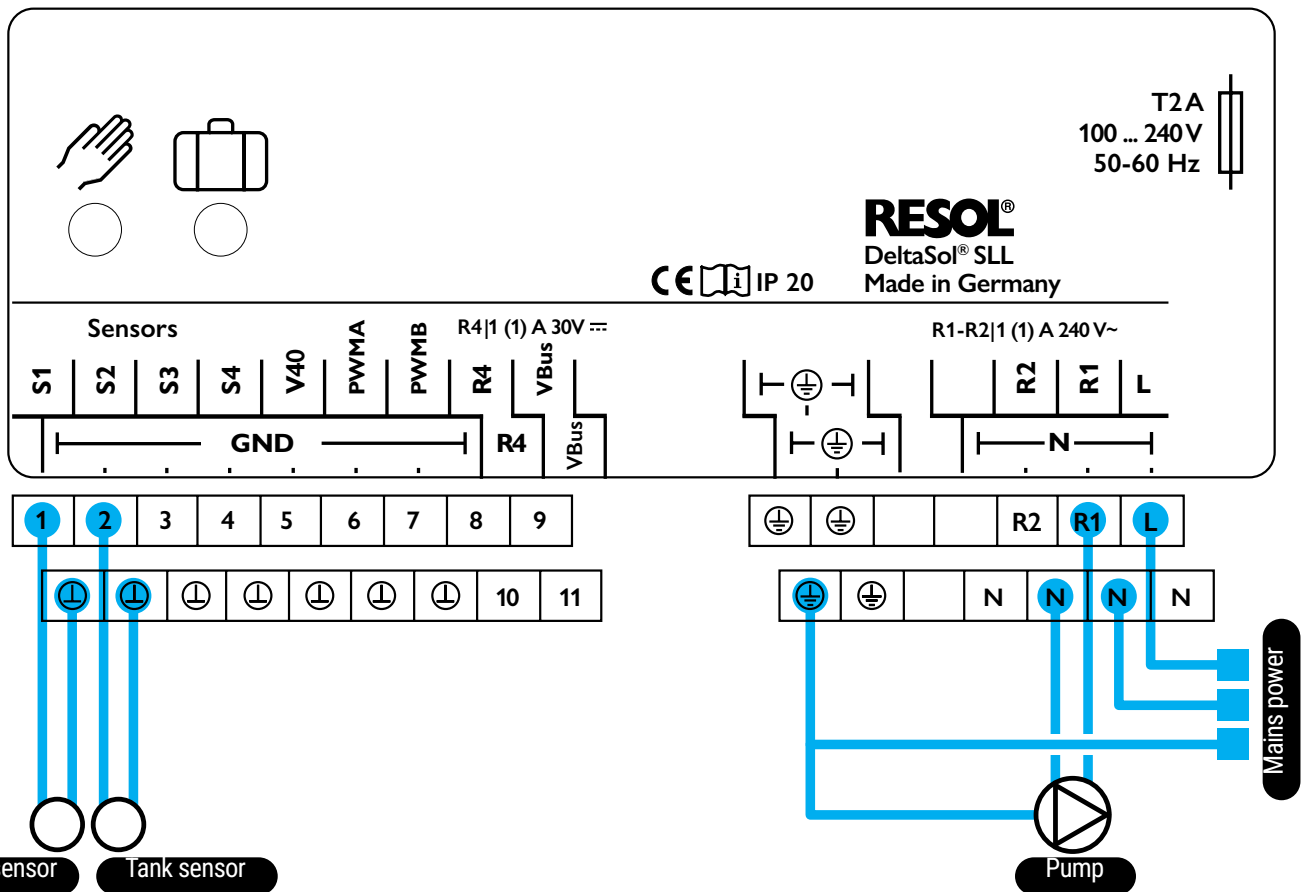

Figure 11. PM-602 wiring diagram

Controller setting



This information is for servicing only. Changing the optimal factory settings will void the warranty. It is not recommended that you run the system in manual for extended periods.

Power on and access Installer Mode

1. Turn the power ON and allow the controller to fully load.
2. Press and hold the **CONFIRM** ✓ button for 3 seconds until the display shows "BALANCE".
3. Turn the rotating dial clockwise until "CODE (INST)" appears.
4. Enter the code 0000 and press **CONFIRM** ✓ until "LST" appears, then press ↩ **BACK**.
5. Press and hold the **CONFIRM** ✓ button again for about 3 seconds to enter CUSTOMER SETTINGS mode.
 - Release once the display shows "TIME" at the top.

Verify and adjust settings

1. The controller should come preset with the Envirosun settings.
2. Turn the rotating dial clockwise to check that all parameters are correct.
3. To adjust a setting, press the **CONFIRM** ✓ button.
 - Adjust to the desired value.
 - Press **CONFIRM** ✓ again to set the value (this stops **SET** from flashing).
4. Rotate clockwise to move to the next parameter and repeat as needed.
5. Once all settings are confirmed, press ↩ **BACK** and proceed with testing to ensure the controller and pump operate correctly.

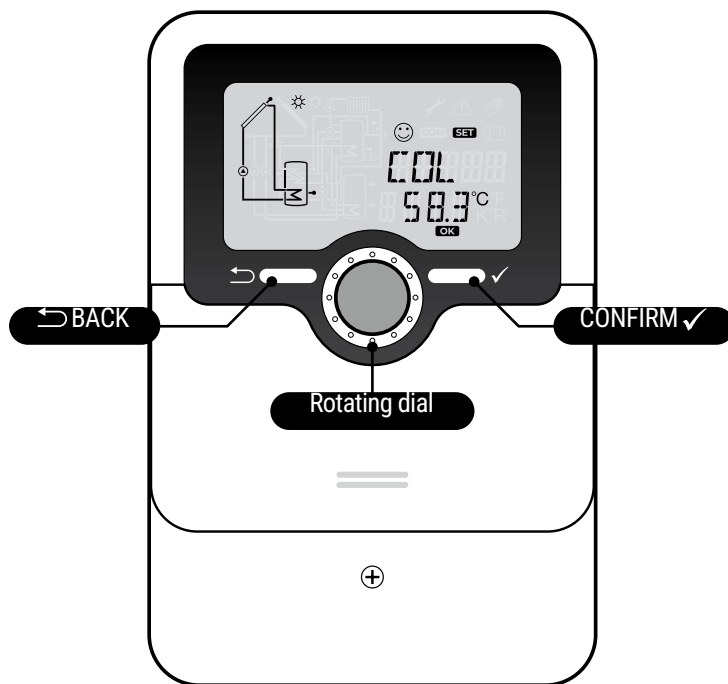

Figure 12. Controller function

Setting	Display	Value
Switch On Temp Diff	DT 0	10.0 K
Switch Off Temp Diff	DT F	1.0 K
S Set	S SET	45 °C
Maximum Store Temp	S MAX	70 °C
LST	LST	ON
Language	LANG	En
Temperature Unit	UNIT	°C
Reset	RESE	
Version number	001	

Table 6. Controller settings

Gas AES installation instructions

- All gas work must comply with local regulations including AS 5701/AG601 and AS/NZ:3500.4.
- All gas work must be conducted by a suitability licensed gas fitter.
- Installation of the gas heater must be installed in accordance with the installation instructions supplied with it.
- Envirosun systems only use approved gas heaters.
- Particular attention must be given to the gas supply system to ensure there is a sufficient gas supply available to the gas heater when operating at full output burner rate.

Approved gas AES models

- Gas heater models used with Envirosun solar water heater systems must be certified to all local requirements, be automatic ignition and have full flame modulation.
- The temperature setting of the gas AES must be permanently set to 70°C.
- Gas heaters other than this type must not be used with a Envirosun solar water heater.
- Fixed pilot and fixed flame gas heater models must not be used under any circumstance.
- Please refer to your local distributor for information on approved gas heater model.

COMMISSIONING & HANDOVER

Commissioning

When all connections have been completed the solar water heater can be filled with water.

1. Before turning on the cold water supply to the system, open one hot tap within the household to release air from the system during the filling process. Do not leave the open tap unattended during the filling process.
2. Turn on the cold water supply and wait for the system to fill.
3. When water flows from the open hot tap without air bursts then the hot tap can be closed. This will now pressurise the solar water heater system.
4. Once the system is pressurised, all connections on the water heater must be checked for leaks and repaired if necessary.
5. When the system is proven water tight, power and/or gas can be applied to the AES system.
6. To test that the element is operational turn the circuit breaker in the switch board on and off, you should see the power meters LED change during this action.
7. For gas AES systems, turn on a hot water tap and the gas heater will ignite provided the water temperature is less than 70°C.
8. Setting the flowrate – the inline flow metre installed in Step 5 under *Connections for the PM-602, page 13*, must be adjusted to the flowrate value in the table below by turning the ball valve until the lower part of the bob lines up with the value in the table below.

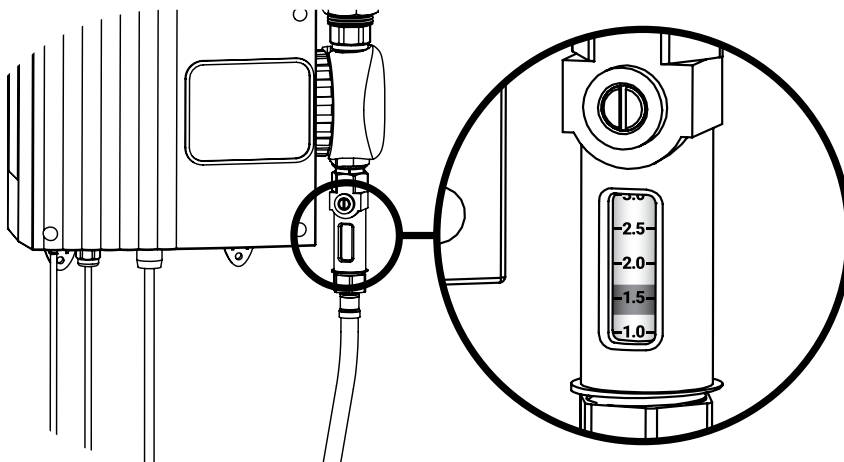

Figure 13. Flow rate meter

Collector Area (m ²)	Flowrate (L/min)
2.5	1.3
4, 5, 6	2.6

Table 7. Flow rates

Customer handover

The solar water heater is now fully operational!

Once the solar water heater is commissioned and you are confident it is operating correctly, complete the Installation Record on the inside cover of this manual. A record of installation can also be completed online at envirosun.au/install and Warranty Registration at envirosun.au/warranty-registration.

Please hand the owner the **Installation and Owners Manual** and the Gas Heater Manual (if gas AES is used).

Before leaving the installation, ensure that the customer is fully aware of the system's operation and whom to contact should there be any questions in the future.

SYSTEM MAINTENANCE

The Envirosun solar water heater is designed so that there is little to do in the way of system maintenance.



WARNING

Personally inspecting or servicing any part of the system is not recommended.

Should you decide that you want to inspect the roof mounted collectors, it is essential that you use all safety devices required to ensure your personal safety. Most importantly the electricity supply must be turned OFF.

Draining and flushing the system



CAUTION

The system must be completely drained of water before any plumbing work is commenced. This will prevent damage to the storage tank in the event of a vacuum or excessive pressure forming at the storage tank.



The Envirosun AS hot water system should be drained and flushed every five years during a major service of the unit.

1. Turn off and isolate the power supply to the electrical element.
2. Turn off the water supply to the water heater.
3. Release excess pressure from the tank by manually opening the pressure & temperature relief valve.
4. Disconnect the cold water supply pipe connection to the tank.
5. Fit a 1/2" flexible drain pipe to the cold connection at the tank. Place the open end of the drain hose in a location where it is safe for the hot water to drain away from the tank.
6. Manually open the pressure & temperature relief valve which will allow air into the tank and the water within the tank will flow out via the flexible drain pipe fitted to the cold inlet connection. Hold the valve open until the tank is empty.
7. To drain the collectors, disconnect the cold pipe from the bottom of the collector array.

Collector glass cleaning

Glass cleaning usually occurs by natural rainfall; however, if the installation is in an industrial (or similar) area with high levels of airborne particles then a qualified person can clean the collector glass with normal window cleaning chemicals and equipment. If rainwater collection occurs from the same roof on which the solar water heater is located, do not use chemical cleaning agents to clean the collectors. Any spillage of these onto the roof could cause contamination of water in the rainwater tank.

Hail damage or broken collector glass

In the unusual case that the toughened glass collector covers are broken, Envirosun does not advise replacement of the glass. The entire panel should be replaced to maintain the performance and integrity of the water heater. Replacement panels should be installed by a qualified person.

Relief valves



The lever on the relief valves should be operated at least every six months. Failure to do so may result in failure of the tank. If water does not discharge freely from the valves they should be checked and possibly replaced. The relief valves and relief valve drain lines must not be blocked. Some water may discharge during each heating cycle.

Every five year's all safety valves should be replaced to ensure continued life and operational safety of the system. In locations where the potable water has a Total Dissolved Solids (TDS) of greater than 600 ppm it is recommended to replace all safety valves every 3 years.

Anode



The high quality vitreous enamel lined low carbon steel tanks have a sacrificial anode for long tank life. This anode should be inspected every few years and be replaced when it has worn out.

As a minimum, it is recommended that the anode be changed every 5 years.



In areas where the water quality characteristics exceed the values in *Table 2, page 8*, it is suggested that the anode be checked and replaced at more frequent intervals.

TROUBLESHOOTING

If there is not enough hot water we recommend that the following points are considered as part of the service call. The most obvious reasons for a lack of hot water could be one of the following.

Low solar energy input

If there have been prolonged periods of cloud or winter is approaching, it may be necessary to reconsider the permitted boosting time for time-clock controlled systems or to turn on the booster for systems with a booster isolation switch.

Solar collector shading

Often trees or other buildings can shade the solar collectors or there can be a dirt build-up on the glass cover. Trees should be cut back if possible or the system relocated if removal of the shading is not possible in the present location. If the glass is dirty this should be cleaned with standard domestic glass cleaner. If rainwater collection occurs from the same roof on which the solar water heater is located, do not use chemical cleaning agents to clean the collectors. Any spillage of these onto the roof could cause contamination of water in the rainwater tank.

AES (booster) system not operating

For electric systems the fuse or circuit breaker supplying the AES System should be checked. If the time clock (where fitted) and the fuse or circuit breaker are operational and the water is cold, you can turn the booster isolator on and off to see if the electricity meter speed changes. If there is no change in speed, it indicates there may be a booster problem. Contact your authorised Envirosun dealer or installation service provider as soon as possible.

For gas systems the gas and electric supplies to the gas heater should be checked to ensure they are both on. If water temperature from the gas heater is below 70°C and both supplies are on and the gas heater does not ignite there may be a problem. Contact your authorised Envirosun dealer or installation service provider as soon as possible.

Excessive water discharge from the valves

It is normal for the Expansion Control valve (ECV) to drip water when heating. If there is a discharge of more than 10 litres per day from any of the systems valves, it indicates there may be a problem with the valve or an increased water supply pressure. Contact your authorised Envirosun dealer or installation service provider as soon as possible.

Hot water use higher than anticipated

Often the hot water usage of showers, washing machines and dishwashers is underestimated by the customer. Review these appliances to determine if the daily usage is greater than the storage volume of the water heater. Depending on the model and conditions, our AS system tanks contain 250 to 400 litres of hot water therefore if the hot water load is greater than the system capacity within a short period of time, there may be periods where the water temperature is lower than normal. It is also advisable to inspect hot water tap washers etc. for leakage and replace if necessary.

Water discharge from the frost valve

If your system has a frost valve fitted it will be located at the bottom corner of the collector. In temperatures that cause frost or freezing the valve will open and some water will discharge from this valve. There is nothing that needs to be done to the valve or the system, it is operating correctly. The water will stop discharging once the valve has warmed enough to close again, usually as the frost clears. Depending on the water quality level or solids that may accumulate in the system, the frost valve may be prevented from closing and sealing properly. If this occurs the system may need to be flushed clean and/or valve replaced.

Refer to *Cold climate installations*, page 3 for more information on frost protection.

Condensation in solar thermal collectors

When the solar thermal collector is exposed to sunlight, it absorbs solar energy and heats up. This heating causes the air inside the collector to be warmer than the external environment, which generally reduces the likelihood of condensation during daylight hours.

After sunset, the collector loses heat rapidly, and the internal air can cool down significantly. If the temperature of the collector's surfaces or the surrounding environment drops more quickly than the air inside, condensation can occur. This happens because the internal surfaces and the glass cover may reach temperatures below the dew point of the air inside, leading to the formation of moisture.

Impact on Performance: It is important to note that while condensation may occur at night due to these temperature changes, it does not affect the overall performance or efficiency of the solar thermal collector. The system is designed to operate effectively regardless of condensation. If you have any concerns or need further assistance, please feel free to contact our support team.

WARRANTY

Warranty terms

This warranty is given by Energie Group Australia Pty Ltd in relation to Envirosun Solar Hot Water Systems (the Product).

The benefits conferred by this warranty are in addition to all other legal rights and remedies of the Customer in respect of the Product. Given installation and application is in accordance with the manufacturer's specifications and instructions, the Product and components are warranted by Envirosun for the cost of labour (from persons approved by Envirosun) and components (as approved by Envirosun) in the event of defects arising from faulty materials and/or workmanship in accordance with the warranty conditions and exclusions stated in this document.

Where the Product is installed outside the boundaries of a Capital City's Metropolitan area or where the Product is installed outside a 25km radius of a Envirosun Dealer business address, the cost of transport, insurance and travelling will be charged to the consumer.

For all new Product purchases through public sales auctions, internet and/or other electronic sales auctions or remote offerings (Excluded Sales), the warranty for the Product is the responsibility of the dealer or reseller of the Product, and not of Envirosun. The terms of the warranty contained in this document will not extend to these Excluded Sales.

Warranty of the Product will remain with the Product for the warranty coverage period as specified in this document.

Warranty definitions

Domestic Use

Warranty periods that are allocated under "Domestic Use" are based on hot water usage patterns of a typical family, for personal hygiene use.

Envirosun "Domestic Use" warranty periods apply to water heaters installed to supply heated water to a single-family domestic dwelling.

Commercial Use

The warranty periods that are allocated under "Commercial Use" are for all other applications other than domestic use as specified above.

Non Residential / commercial use warranty is limited to product only for 1 year.

Warranty conditions

The initial point of contact for all Warranty claims is the Envirosun Dealer from whom the Product was purchased.

Notification

All warranty claims must be reported to Envirosun no later than 14 days from the date the fault is reported to the Envirosun Dealer. All terms of this warranty are effective from the date of installation of the Product and the attending service person reserves the right to verify this date by requesting a copy of the certificate of compliance, installation record issued by an appropriately qualified installer or proof of purchase prior to the commencement of any warranty work.

Installation

The Product must have been installed, commissioned, serviced, repaired and removed by a licensed gasfitter or plumber in accordance with the manufacturer's installation instructions, current AS/NZS 3000, AS/NZS 3500, AS/NZS 5601, applicable laws, local regulations and municipal building codes by persons authorised by local regulations to do so. Cost of labour or materials to remedy an installation that does not comply with these requirements is not covered by the warranty and will be at the cost of the installer.

Maintenance and operation

The Product must be operated and maintained in accordance with Envirosun's operating instructions. This warranty only applies to the Product as supplied by Envirosun and does not apply to any additional electrical and/or plumbing parts supplied by the installer.

Location

Where the Product has not been sited in accordance with the installation instructions or installed such that normal service access is difficult, a service charge may apply and this service charge will not be included in the warranty. If, at the discretion of the attending service person, access is assessed as dangerous, service will be refused and the warranty will not apply.

Any work required to gain reasonable access to the Product will be chargeable to the customer by the attending service person including, but not limited to, removal of cupboards, doors, walls, or the use of special equipment to move components to floor level. The cost of access as specified in this paragraph is not included in the warranty. The Product is covered under warranty for the indicated period (see the section titled Warranty Period below) from the date of installation. Should a part of the complete Product be replaced during this period, only the balance of the original warranty from the date of the installation of the original Product (and not the new part) will continue to remain effective.

Water connection

This warranty applies to the Product when it is connected directly to a reticulated water supply from a state approved water utility.

This warranty does not apply if the Product is connected to any alternative water supplies if the water chemistry and impurity levels of alternative water supplies exceed the limits specified in *Table 2, page 8*.

Examples of alternative water supplies which are covered under the warranty are private bore water, water from private dams, rain water tanks (subject to the terms of this document) and water supplied from a reticulated water supply but where the water chemistry is deliberately altered before supplying the water heater.

Should the Product be installed in a regional location where regular flushing is required due to sediment build-up, the drain cock for flushing must be fitted at the time of installation at the customer's expense in order for the warranty to be applicable.

A warranty will apply to rain water tanks, as alternative water supply, ONLY in circumstances where rain water is filtered and free of any physical or sediment debris and water quality does not exceed the limits specified in *Table 2, page 8*.

Product variations

Component manufacturers are at liberty to alter the design or construction of the components of the Product. Subject to the law, provided the parts of the Products are of the same or similar quality and are fit for the purposes for which they are purchased, such alterations shall not constitute a defect in design or construction under this warranty.

Envirosun reserves the right to alter the design or construction of the Product within allowance of the relevant Standard(s), industrial and State and Territory legislation without notice. Envirosun warrants to the original purchaser, or for Product purchased from a Reseller, to the original end user, that the Product will be free from any defects in materials and workmanship from the date of shipment or invoice or, if longer, the period stated in this policy in accordance with the warranty terms in Table 2. During the warranty period, Envirosun will, subject to the terms of this document, at its option apply one of the three following remedies:

- i. provide replacement parts necessary to repair the Product,
- ii. replace the Product with same Product or similar approved newer design,
- iii. refund the amount purchaser paid, LESS DEPRECIATION, upon its return.

Labour costs

Envirosun or an Envirosun Dealer will provide labour to resolve warranty issues during the warranty period. Repair service shall be available at the purchaser's location. Envirosun will determine how and where repair services are provided, and the purchaser may, at Envirosun's reasonable cost, be required to deliver product to an authorised location.

Replacement parts

Replacement parts and/or Product will be new or serviceably used, comparable in function and performance to the original part or Product and warranted for the remainder of the original warranty period. Purchasing additional parts for the Product or seeking a replacement of the Product or parts of the Product from Envirosun does not extend your warranty period.

If Envirosun requires the return of defective parts/Products, the Envirosun Dealer/purchaser shall return them within 14 days of the request by Envirosun. Failure to return defective parts will attract charges for replaced parts/system and their shipment to the Envirosun Dealer/purchaser.

Warranty period

Envirosun offers 12 months comprehensive warranty for the Product including parts and labour.
10-year warranty to original owner/occupier only. Other owners limit to 5-year warranty.

Component	Up to 1 year	From 1-2 years	From 2-5 years	From 5-10 years
	Parts and labour		Parts only	
DOMESTIC	AS Tank (ground mounted)	✓	✓	✓
	Collector	✓	✓	✓
	PM-602 ¹	✓	✓	✗
	Electrical components, valves and plumbing accessories	✓	✗	✗
¹ In order to comply with Victorian State legislation, in Victorian domestic installations only, 5-year warranty on the solar circulating pump & solar controller applies.				

Component	From 10 years
AS Tank (ground mounted)	✓
Collector	✓

Commercial use is limited to 3 years parts only.

Warranty exclusions

The following exclusions will cause the warranty to become void and may at Envirosun's absolute discretion incur a service charge and cost of parts that may be required. The exclusions do not limit any other term of this document including any other term or condition of the warranty.

1. Accidental damage, failure due to misuse, abuse and accidents.
2. Failure due to incorrect installation and/or attempts to repair the Product other than by an Envirosun Dealer and/or approved service personnel.
3. Failure to install, commission, service, repair and remove the Product in accordance with the manufacturers installation instructions, current AS/NZS 3000, AS/NZS 3500, AS/NZS 5601, local regulations and municipal building codes by persons authorised to do so.
4. Failure due to use of parts other than Envirosun branded/approved parts.
5. Where the solar collector leaks or fails to operate normally due to frost or freezing, unless the Product has been installed under a Sustainability Victoria program requiring frost warranty or other such similar State administered program.
6. Damage and/or breakage to the collector glass.
7. Where the Product component has failed directly or indirectly as a result of excessive water pressure, negative pressure (partial vacuum), corrosive atmosphere, faulty plumbing and/or electrical wiring, or major variations in electrical energy supply.
8. Where the water stored in the cylinder exceeds at any time levels as per *Table 2, page 8*.
9. Any serial tags/stickers on any of the components are removed or defaced.
10. The Product is relocated from its original point of installation.
11. This warranty does not cover:
 - a. claim for damage to walls, foundations, gardens, etc. or any other consequential loss or inconvenience either directly or indirectly due to leakage from the solar water heating system or any other matter related to the system or its operation.
 - b. the effects of sludge/sediment as a result of connection to a water supply from suitably filtered or treated sources e.g. spring, dam, bore or river.
12. Consequential damage or any incidental damage.
13. Maintenance, repair or replacement of parts due to normal wear and tear.
14. Damage/problems caused by storm, fire, flood, vandalism, misuse, negligence, Acts of God, earthquake, war, vermin or foreign matter entering the equipment
15. Repairs to Product where the Product is used for a purpose other than its intended purpose.
16. Repairs necessitated due to accident, neglect, improper storage or misuse.
17. Normal maintenance recommended by this document.
18. Unauthorised modifications, or external interference.



Our goods come with guarantees that cannot be excluded under the Australian Consumer Law. You are entitled to a replacement or refund for a major failure and for compensation for any other reasonably foreseeable loss or damage. You are also entitled to have the goods repaired or replaced if the goods fail to be of acceptable quality and the failure does not amount to a major failure.

To make a claim against this warranty, you must, within the applicable warranty period, contact the relevant Envirosun dealer or Envirosun, using the contact details below.

OH&S Disclaimer

Envirosun and its Authorised Dealers work with and recommend various installation and plumbing companies to install, test and certify correct operation of solar hot water systems or the Product. Envirosun is a supplier of systems only.

Each installation must be covered by the installer's insurances, commercial terms and conditions and by the applicable OH&S legislation. Each person that installs assembles or services must comply with all OH&S requirements relevant to the type of work being conducted including, but not limited to, plumbing work, work on heights exceeding 2.5m and electrical work. The customer must ensure that it complies with all its OH&S obligations. This warranty will be void if these conditions are not met.

Thank you for installing our world class Envirosun solar water heater!

CONTACT DETAILS

For further information, please call one of the following phone numbers from anywhere in Australia:

Energie Group Australia Pty Ltd	460 Victoria Road, MALAGA WA 6090	www.energiegroup.au
	Sales and Support:	1300 046 893 info@energiegroup.com.au
	For downloads and information:	www.envirosun.au

THIS PAGE INTENTIONALLY LEFT BLANK



 **1300 046 893**
Technical Support

 **info@energiegroup.com.au**
Email

 **envirosun.au**
Downloads & Info